

Flexim FLUXUS G831 Ultrasonic Flowmeter



Ultrasonic Gas Flowmeters for Permanent Installation in Hazardous Areas

Features



- Two measuring channels
- Flameproof/explosion proof housing for hazardous areas
- Intrinsic safe process inputs for the integration of external pressure and temperature sensors
- More precise measurement at unfavorable measuring points through integrated disturbance correction
- Bidirectional communication and support of common bus technologies (Profibus PA, Foundation Fieldbus, HART, Modbus, BACnet)
- Certification: ATEX/IECEX zone 1, FM Class I Div. 1+2

Applications

- Chemical industry
- Petrochemical industry
- Oil and gas industry



Transmitter

Technical data

	FLUXUS G831 (ATEX/IECEX intrinsically safe inputs/outputs Ex ia)	FLUXUS G831 (ATEX/IECEX no intrinsically safe inputs/outputs)	FLUXUS G831 (FM Class I Div. 1)
			
design	<ul style="list-style-type: none"> intrinsically safe outputs no inputs intrinsically safe process interface (optional) 	<ul style="list-style-type: none"> intrinsically safe outputs intrinsically safe inputs intrinsically safe process interface (optional) 	<ul style="list-style-type: none"> outputs: no intrinsic safety inputs: no intrinsic safety process interface (optional): no intrinsic safety
certification type	831-AAF, 831-AAN, 831-SAF, 831-SAN	831-ABF, 831-ABN, 831-SBF, 831-SBN	831-ANN, 831-SNN, G831**-F1N...
measurement			
measurement principle	transit time difference correlation principle		
flow direction	bidirectional		
synchronised channel averaging	x (2 measuring channels necessary)		
flow velocity	m/s measuring range: 0.01...35, depending on pipe diameter		
repeatability	0.15 % MV ±0.005 m/s		
fluid	all acoustically conductive gases, e.g. nitrogen, air, oxygen, hydrogen, argon, helium, ethylene, propane		
temperature compensation	corresponding to the recommendations in ANSI/ASME MFC-5.1-2011		
measurement uncertainty (volumetric flow rate)			
measurement uncertainty of the measuring system ¹	±0.3 % MV ±0.005 m/s		
measurement uncertainty at the measuring point	±1...2 % MV ±0.005 m/s, depending on the application		
transmitter			
power supply	20...32 V DC, U _m = 120 V		<ul style="list-style-type: none"> 100...240 V/50...60 Hz or 20...32 V DC
power consumption	W	< 4	< 8
number of measuring channels		1, optional: 2	
damping	s	0...100 (adjustable)	
measuring cycle	Hz	100...1000 (1 channel)	
response time	s	1 (1 channel), option: 0.02	
housing material		aluminum housing: cast aluminum EN AC 44200 mod, special heavy-duty coating (C5 according to EN ISO 12944) stainless steel housing: stainless steel 316/316L (1.4401, 1.4404, 1.4432)	cast aluminum EN AC 44200 mod, special heavy-duty coating (C5 according to EN ISO 12944)
degree of protection		IP66	TYPE 4X/IP66
dimensions	mm	see dimensional drawing	
mounting position		831-A*F (Profibus PA, FF H1), 831-S**: nameplate faces upwards	-
weight	kg	aluminum housing: 6.5, stainless steel housing: 15.6	
fixation		wall mounting, 2" pipe mounting	
ambient temperature	°C	aluminum housing: <ul style="list-style-type: none"> -40*...+65** 831-A*F (Profibus PA, FF H1): -40*...+50 stainless steel housing: <ul style="list-style-type: none"> -20...+60 831-S*F (Profibus PA, FF H1): -20...+50 * < -20 without operation of the display **outside the explosive atmosphere	aluminum housing: <ul style="list-style-type: none"> -40*...+65** -40*...+60 active current output or HART active or > 1 passive current output and current input or HART passive and current input stainless steel housing: <ul style="list-style-type: none"> -20...+60 * < -20 without operation of the display **outside the explosive atmosphere
display		128 x 64 pixels, backlight	
menu language		English, German, French, Spanish, Dutch, Russian, Polish, Turkish, Italian, Chinese	

¹ with aperture calibration of the transducers

² outside the explosive atmosphere (housing cover open)

	FLUXUS G831 (ATEX/IECEx intrinsically safe inputs/outputs Ex ia)	FLUXUS G831 (ATEX/IECEx no intrinsically safe inputs/outputs)	FLUXUS G831 (FM Class I Div. 1)
explosion protection			
• ATEX/IECEx			
marking	<p>CE 0637 II2G II2D UK CA Ex db eb ia IIC T6 Gb Ex tb ia IIIC T100 °C Db 831-ANN: T_a -40...+60 °C 831-SAN: T_a -20...+60 °C 831-AAF: T_a -40...+50 °C 831-SAF: T_a -20...+50 °C</p>	<p>CE 0637 II(1)2G II(1)2D UK CA Ex db eb ia [ia Ga] IIC T6 Gb Ex tb ia [ia Da] IIIC T100 °C Db 831-ABN: T_a -40...+60 °C 831-SBN: T_a -20...+60 °C 831-ABF: T_a -40...+50 °C 831-SBF: T_a -20...+50 °C</p>	<p>CE 0637 II2G II2D UK CA Ex db eb IIC T6 Gb Ex tb IIIC T100 °C Db 831-ANN: T_a -40...+60 °C 831-SNN: T_a -20...+60 °C</p>
certification	IBExU20ATEX1103 X, IECEx IBE 20.0015X	IBExU20ATEX1103 X, IECEx IBE 20.0015X	IBExU20ATEX1103 X, IECEx IBE 20.0015X
• FM			
marking	-	-	<p> Cl. I, II, III, Div. 2, GP A, B, C, D, F, G / T4A Cl. I Div. 1, GP. A, B, C, D / T6 For Group A, conduit seal of connection compartment is required within 18 inches. Cl. II, Div. 1, GP. E, F, G / T6 Cl. III, Div. 1 / T6 T_a = -40°C to +60°C</p> <p> Cl. I, II, III, Div. 2, GP A, B, C, D, F, G / T4A Cl. I Div. 1, GP. B, C, D / T6 Cl. II, Div. 1, GP. E, F, G / T6 Cl. III, Div. 1 / T6 T_a = -40°C to +60°C</p>
measuring functions			
physical quantities	operating volumetric flow rate, standard volumetric flow rate, mass flow rate, flow velocity, optional: gas energy flow rate (DGM)		
totaliser	volume, mass, optional: gas energy (DGM)		
calculation functions	average, difference, sum (2 measuring channels necessary)		
diagnostic functions	sound speed, signal amplitude, SNR, SCNR, standard deviation of amplitudes and transit times		
communication interfaces			
service interfaces	measured value transmission, parametrisation of the transmitter: USB ²		
process interfaces	intrinsic safety, max. 1 option: • HART • Profibus PA • FF H1	max. 1 option: • Modbus RTU/RS485 • HART • Profibus PA • FF H1 • BACnet MS/TP	
intrinsic safety parameters	Profibus PA, FF H1: U _i = 24 V I _i = 174 mA P _i = 1044 mW L _i = 10 µH C _i negligible		
accessories			
data transmission kit	USB cable		
software	• FluxDiag Reader: reading of measured values and parameters, graphical representation • FluxDiag (optional): reading of measurement data, graphical representation, report generation, parametrisation of the transmitter		
data logger			
loggable values	all physical quantities, totalised physical quantities and diagnostic values		
capacity	max. 800 000 measured values		

¹ with aperture calibration of the transducers

² outside the explosive atmosphere (housing cover open)

	FLUXUS G831 (ATEX/IECEx intrinsically safe inputs/outputs Ex ia)	FLUXUS G831 (ATEX/IECEx no intrinsically safe inputs/outputs)	FLUXUS G831 (FM Class I Div. 1)
outputs			
The outputs are galvanically isolated from the transmitter.			
• switchable current output			
		configurable according to NAMUR NE 43 All switchable current outputs are jointly switched to active or passive.	
number			max. 3
range	mA		4...20 (alarm current: 3.2...3.99, 20.01...24, hardware fault current: 3.2)
uncertainty			0.04 % of output value ±3 µA
active output			R _{ext} = 250...530 Ω, U _{opencircuit} = 28 V DC
passive output			U _{ext} = 9...30 V DC, depending on R _{ext} (R _{ext} < 458 Ω at 20 V)
current output in HART mode			option
• range	mA		4...20 (alarm current: 3.5...3.99, 20.01...22, hardware fault current: 3.2)
• active output			R _{ext} = 250...530 Ω, U _{opencircuit} = 28 V DC
• passive output			U _{ext} = 9...30 V DC, depending on R _{ext} (R _{ext} = 250...458 Ω at 20 V)
• current output			
		configurable according to NAMUR NE 43	
range	mA	4...20 (alarm current: 3.2...3.99, 20.01...24, hardware fault current: 3.2)	-
uncertainty		0.04 % of output value ±3 µA	-
passive output		U _{ext} ≤ 29 V DC, depending on R _{ext} (R _{ext} < 458 Ω at 20 V)	-
current output in HART mode		option	
• range	mA	4...20 (alarm current: 3.5...3.99, 20.01...22, hardware fault current: 3.2)	-
• passive output		U _{ext} = 9...29 V DC, depending on R _{ext} (R _{ext} = 250...458 Ω at 20 V)	-
intrinsic safety parameters		U _i = 29 V I _i = 100 mA P _i = 0.725 W C _i = 1 nF L _i = 50 nH	-
• digital output			
functions		<ul style="list-style-type: none"> • frequency output • binary output • pulse output 	<ul style="list-style-type: none"> • frequency output • binary output • pulse output
type		open collector (passive) (IEC 60947-5-6)	open collector (passive) (IEC 60947-5-6)
operating parameters		6...29 V, I _{max} = 15 mA, R _{int} = 1020 Ω Low: U < 2 V at I _{loop} = 2 mA (R _{ext} = 11 kΩ at U _{ext} = 24 V) High: U > 15 V (R _{ext} = 11 kΩ at U _{ext} = 24 V)	5...30 V, I _{max} = 20 mA, R _{int} = 1020 Ω Low: U < 2 V at I _{loop} = 2 mA (R _{ext} = 11 kΩ at U _{ext} = 24 V) High: U > 15 V (R _{ext} = 11 kΩ at U _{ext} = 24 V)
frequency output			
• range	kHz	0.002...10	0.002...10
• damping	s	0...999.9 (adjustable)	0...999.9 (adjustable)
• pulse-to-pause ratio		1:1	1:1
binary output			
• binary output as alarm output		limit, change of flow direction or error	limit, change of flow direction or error
pulse output			
• pulse value	units	0.01...1000	0.01...1000
• pulse width	ms	0.05...1000	0.05...1000
• pulse rate		max. 10 000 pulses	max. 10 000 pulses
intrinsic safety parameters		U _i = 29 V I _i = 100 mA P _i = 0.725 W C _i = 1 nF L _i = 50 nH	-

¹ with aperture calibration of the transducers

² outside the explosive atmosphere (housing cover open)

	FLUXUS G831 (ATEX/IECEx intrinsically safe inputs/outputs Ex ia)	FLUXUS G831 (ATEX/IECEx no intrinsically safe inputs/outputs)	FLUXUS G831 (FM Class I Div. 1)
inputs			
	not short-circuit proof The inputs are not galvanically isolated from the transmitter.	The inputs are galvanically isolated from the transmitter.	
• temperature input			
number	-	max. 1	max. 1
type	-	Pt100/Pt1000	Pt100/Pt1000
connection	-	4-wire	4-wire
range	°C	-150...+560	-150...+560
resolution	K	0.01	0.01
accuracy	-	±0.01 % MV ±0.03 K at 18...28 °C ±0.01 % MV ±0.03 K ±0.0005 %/K at <18 °C/>28 °C	±0.01 % MV ±0.03 K at 18...28 °C ±0.01 % MV ±0.03 K ±0.0005 %/K at <18 °C/>28 °C
cable resistance	Ω	max. 1000	max. 1000
intrinsic safety parameters	-	U _o = 9.2 V I _o = 25 mA P _o = 0.057 W C _o = 4283 nF L _o = 57 mH	-
• switchable current input			
	All switchable current inputs are jointly switched to active or passive.		
number	-	max. 2	
accuracy	-	±0.1 % MV ±0.01 mA at 18...28 °C ±0.1 % MV ±0.01 mA ±0.005 %/K at <18 °C/>28 °C	
resolution	µA	0.1	
active input	-	R _{int} = 75 Ω, I _{max} ≤ 30 mA U _{opencircuit} = 28 V (open circuit) U _{min} = 21.4 V at 20 mA	
• range	mA	0...20	
passive input	-	U _{ext} = 24 V, R _{int} = 35 Ω, I _{max} ≤ 24 mA	
• range	mA	0...20	
• current input			
number	-	max. 1	-
accuracy	-	±0.1 % MV ±0.01 mA at 18...28 °C ±0.1 % MV ±0.01 mA ±0.005 %/K at <18 °C/>28 °C	-
resolution	µA	0.1	-
active input	-	U _{int} < 20 V, R _{int} ≤ 385 Ω, I _{max} ≤ 40 mA U _{min} = 19.6 V - R _{int} · I	-
• range	mA	0...20	-
intrinsic safety parameters	-	U _o = 29.2 V I _o = 88 mA P _o = 0.64 W C _o = 73 nF L _o = 4.1 mH	-

¹ with aperture calibration of the transducers

² outside the explosive atmosphere (housing cover open)

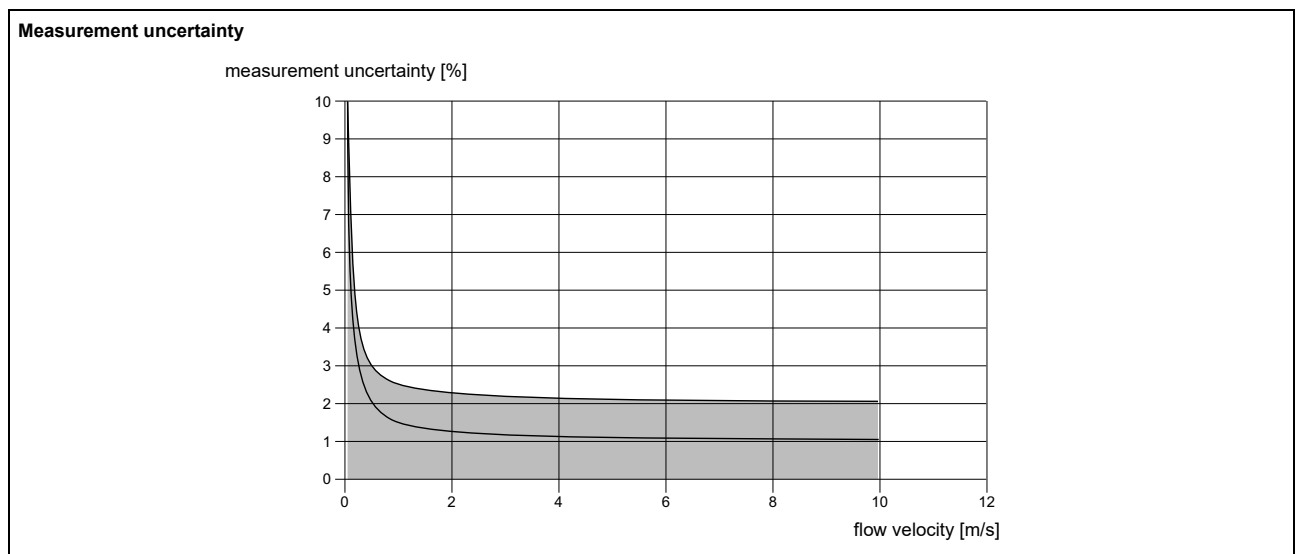

Dimensions

***831 (aluminum housing)**

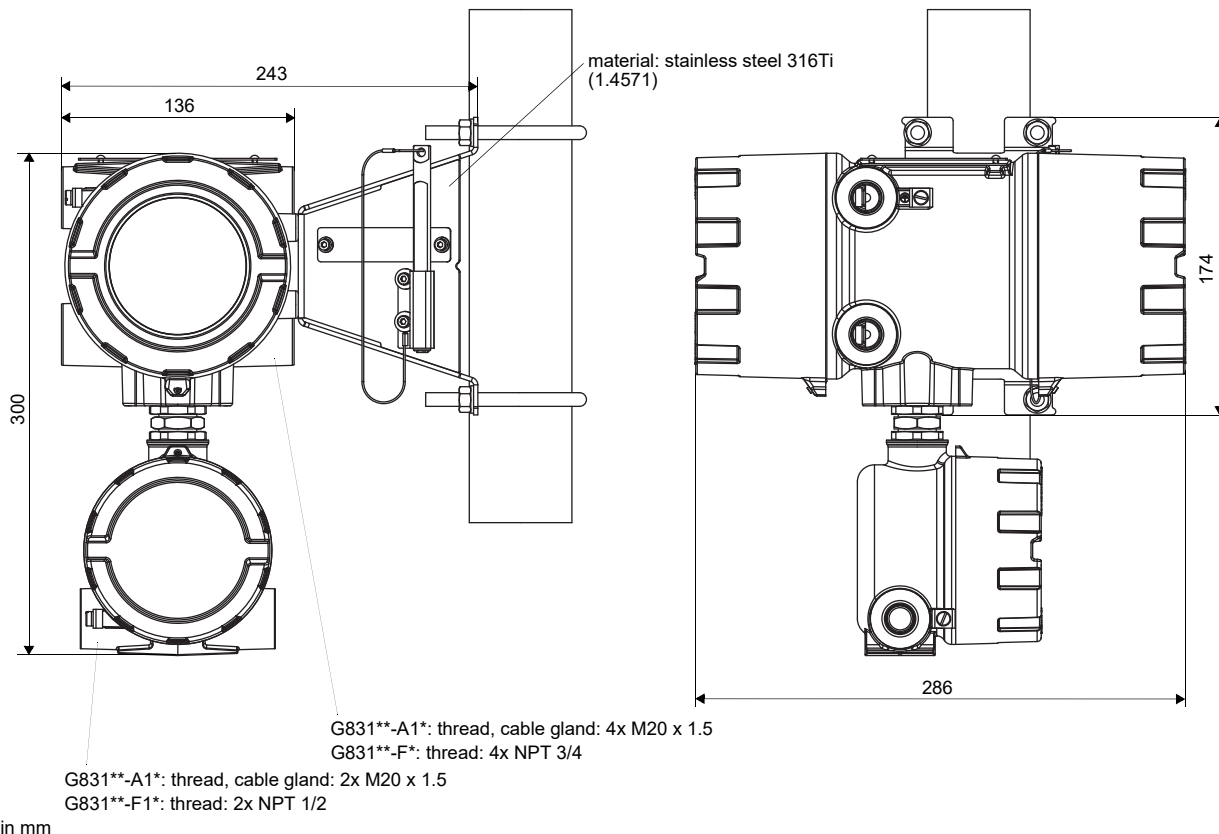

***831 (stainless steel housing)**

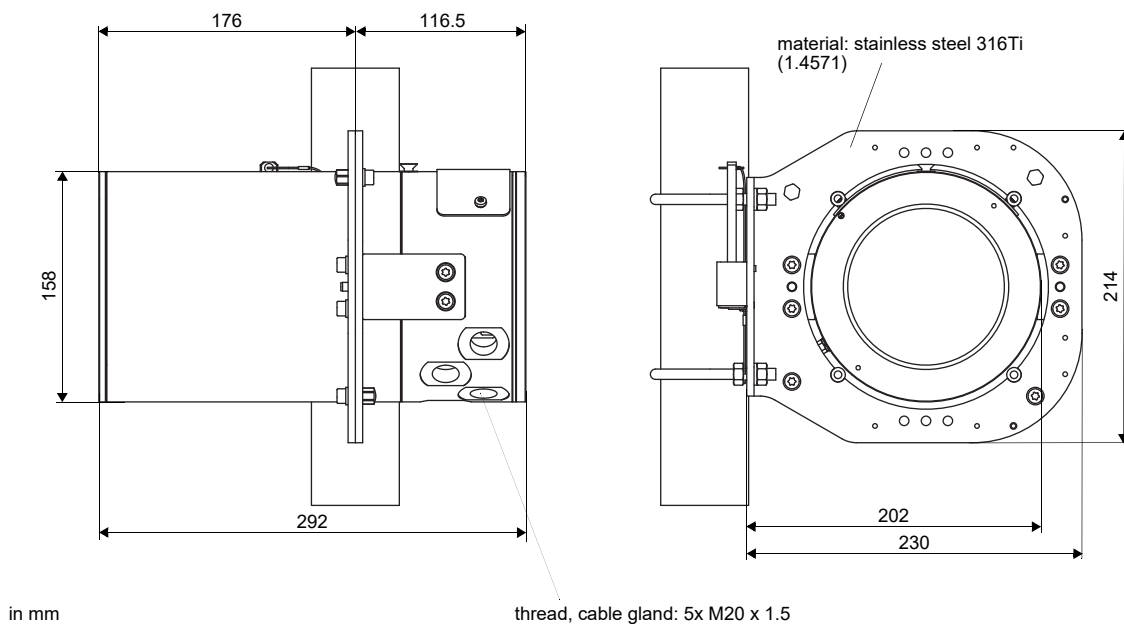

Wall and 2" pipe mounting kit

*831 (aluminum housing)

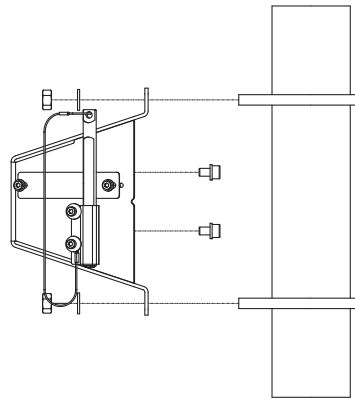

*831 (stainless steel housing)

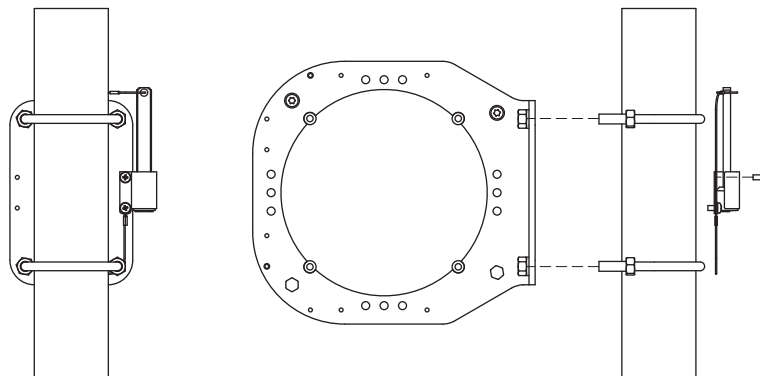

Strap wrench

*831 strap wrench (stainless steel housing)

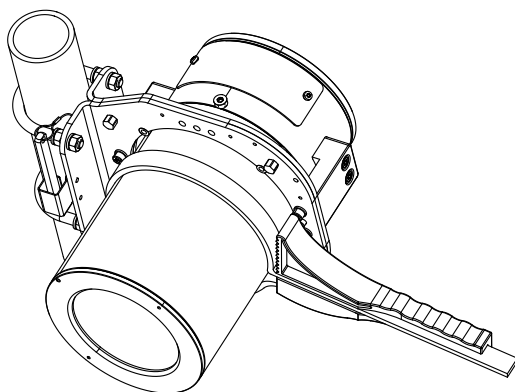

item number: 990224-6

Storage

- do not store outdoors
- store within the original package
- store in a dry and dust-free place
- protect against sunlight
- keep all openings closed
- storing temperature:
 - aluminum housing: -40...+60 °C
 - stainless steel housing: -20...+60 °C

Terminal assignment

***831 (aluminum housing)**

upper housing,
back view
831-AA*, 831-AB*: Ex e, Ex i
831-ANN: Ex e
*831**-F*: XP, DIP, NI

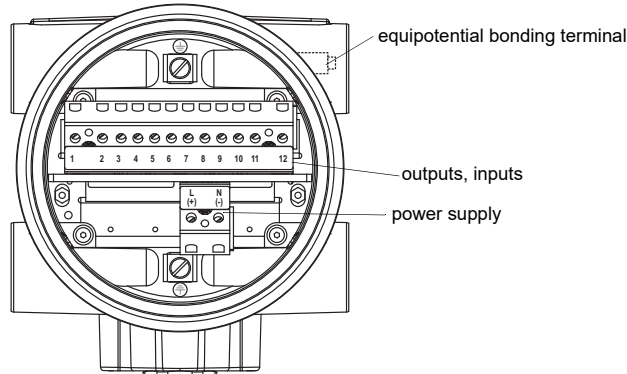

lower housing,
front view
831-A**: Ex e
*831**-F*: XP, DIP, NI

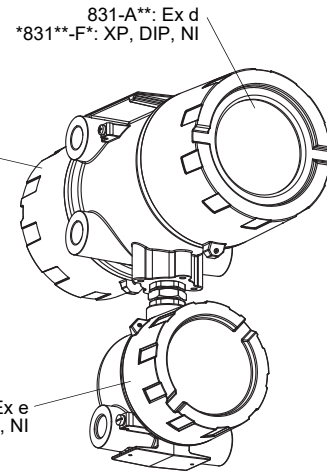
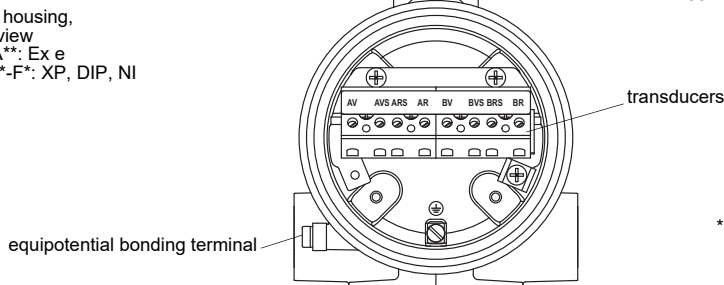

***831 (stainless steel housing)**

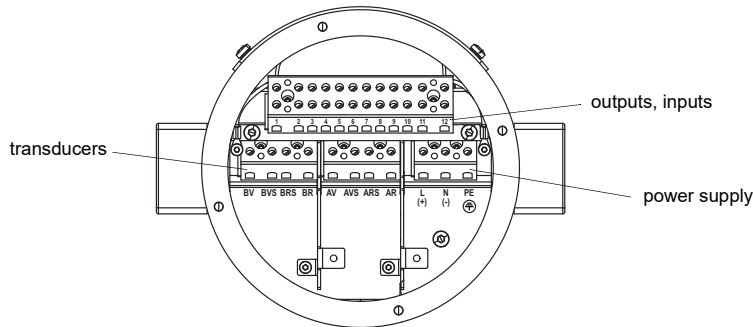

power supply¹

AC		DC	
terminal	connection	terminal	connection
L	line conductor	(+)	+
N	neutral conductor	(-)	-
PE	protective conductor	PE	protective conductor

¹ cable (by customer): e.g. flexible wires, with insulated wire ferrules, wire cross-section: 0.25...2.5 mm²

transducers, extension cable

measuring channel A		measuring channel B		transducer
terminal	connection	terminal	connection	
AV	signal	BV	signal	↑
AVS	internal shield	BVS	internal shield	↕
ARS	internal shield	BRS	internal shield	↕
AR	signal	BR	signal	↕
cable gland	external shield	cable gland	external shield	↑ ↕

outputs, inputs^{1, 2}		
terminal	connection	
depending on configuration	current output, digital output, current input	
3, 4, 5, 6	temperature input	
11+, 12-	passive current output/HART	
11-, 12+	active current output/HART	
11, 12	Modbus RTU, FF H1, Profibus PA, BACnet MS/TP	
temperature probe		
terminal	direct connection	connection with extension cable
3	red	blue
4	white	grey
5	red	white
6	white	red
USB	type C Hi-Speed USB 2.0 Device	service (FluxDiag/FluxDiag Reader)

¹ cable (by customer): e.g. flexible wires, with insulated wire ferrules, wire cross-section: 0.25...2.5 mm²

² The number, type and terminal assignment are customised.

Transducers

Overview

Shear wave transducers

	technical type					
	G	K	M	P	Q	
zone 1 normal temperature range	GDG1N81 GLG1N81	GDK1N81 GLK1N81	GDM2N81 GLM2N81	GDP2N81 GLP2N81	GDQ2N81 GLQ2N81	
zone 1 IP68	GDG1LI1	GDK1LI1	GDM2LI1	GDP2LI1		
zone 1 extended temperature range	GDG1E83 GLG1E83	GDK1E83 GLK1E83	GDM2E85 GLM2E85	GDP2E85 GLP2E85	GDQ2E85 GLQ2E85	
FM Class I Div. 1 normal temperature range	GDG1N62 GLG1N62	GDK1N62 GLK1N62	GDM1N62 GLM1N62	GDP1N62 GLP1N62	GDQ1N62 GLQ1N62	
FM Class I Div. 2 normal temperature range	GDG1N53 GLG1N53	GDK1N53 GLK1N53	GDM2N53 GLM2N53	GDP2N53 GLP2N53	GDQ2N53 GLQ2N53	
FM Class I Div. 2 extended temperature range	GDG1E53 GLG1E53	GDK1E53 GLK1E53	GDM2E53 GLM2E53	GDP2E53 GLP2E53	GDQ2E53 GLQ2E53	
inner pipe diameter d						
min. extended	mm	180	60	30	15	7
min. recommended	mm	220	80	40	20	10
max. recommended	mm	900	300	150	50	22
max. extended	mm	1100	360	180	60	30
pipe wall thickness						
min.	mm	11	5	2.5	1.2	0.6
fluid pressure						
min. extended	bar	metal pipe: 20				
min.	bar	metal pipe: 30, plastic pipe: 1				





for further data see Technical specification TS_G8xx-transducersVx-xxx_Leu

Lamb wave transducers

	technical type							
	F	G	H	K	M	P	Q	
zone 1 normal temperature range	GRF1N83 GTF1N83	GRG1N83 GTG1N83	GRH1N83 GTH1N83	GRK1N83 GTK1N83	GRM1N83 GTM1N83	GRP1N83 GTP1N83	GRQ1N83 GTQ1N83	
zone 1 higher temperatures		GRG1S83 GTG1S83	GRH1S83 GTH1S83	GRK1S83 GTK1S83	GRM1S83 GTM1S83			
zone 1 IP68	GRF1LI3	GRG1LI3	GRH1LI3	GRK1LI3	GRM1LI3	GRP1LI3		
FM Class I Div. 1		GRG1N62 GTG1N62	GRH1N62 GTH1N62	GRK1N62 GTK1N62	GRM1N62 GTM1N62	GRP1N62 GTP1N62	GRQ1N62 GTQ1N62	
FM Class I Div. 2	GRF1N53 GTF1N53	GRG1N53 GTG1N53	GRH1N53 GTH1N53	GRK1N53 GTK1N53	GRM1N53 GTM1N53	GRP1N53 GTP1N53	GRQ1N53 GTQ1N53	
FM Class I Div. 2 higher temperatures		GRG1S53 GTG1S53	GRH1S53 GTH1S53	GRK1S53 GTK1S53	GRM1S53 GTM1S53			
fluid pressure								
min. extended	bar	metal pipe: 10	metal pipe: 10	metal pipe: 10	metal pipe: 10 (d > 120 mm) 3 (d < 120 mm)	metal pipe: 3 (d < 60 mm)	metal pipe: 3 (d < 35 mm)	metal pipe: 3 (d < 15 mm)
min.	bar	metal pipe: 15 plastic pipe: 1	metal pipe: 15 plastic pipe: 1	metal pipe: 15 plastic pipe: 1	metal pipe: 15 (d > 120 mm) 10 (d < 120 mm) plastic pipe: 1	metal pipe: 10 (d > 60 mm) 5 (d < 60 mm) plastic pipe: 1	metal pipe: 10 (d > 35 mm) 5 (d < 35 mm) plastic pipe: 1	metal pipe: 10 (d > 15 mm) 5 (d < 15 mm) plastic pipe: 1
inner pipe diameter d								
min. extended	mm	220	180	110	60	30	15	7
min. recommended	mm	270	220	140	80	40	20	10
max. recommended	mm	1200	900	600	300	150	50	22
max. extended	mm	1600	1400	1000	360	180	60	30
pipe wall thickness ****N** , ****L**								
min.	mm	15	11	8	5	2.5	1.2	0.6
max.	mm	32	24	16	10	5	3	1.2
max. extended	mm	35	-	-	-	-	-	-
pipe wall thickness ****S**								
min.	mm		10.6	7.1	4.2	2.1		
max.	mm		23.7	15.8	9.5	4.7		

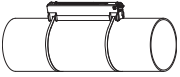
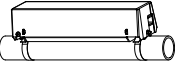
for further data see Technical specification TS_G8xx-transducersVx-xxx_Leu

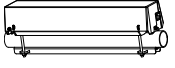
Transducer mounting fixture

Variofix L	Variofix C	PermaFix
		
	Variofix C with bolt mounting plates	PermaFix with bolt mounting plates
	 outer pipe diameter: VCM: max. 46 mm VQC: max. 36 mm	

for further data see Technical specification TS_G8xx-transducersVx-xxx_Leu

Coupling materials for transducers

	normal temperature range (4th character of transducer order code = N)		extended temperature range higher temperatures (4th character of transducer order code = E, S)		
	< 100 °C	< 130 °C	< 180 °C	< 200 °C	200...240 °C
< 24 h	coupling compound type N or coupling foil type VT	coupling compound type N or E or coupling foil type VT	coupling compound type E or coupling foil type VT	coupling compound type E or coupling foil type VT	coupling compound type H or coupling foil type TF
long time measurement	coupling foil type VT	coupling foil type VT	coupling foil type VT	coupling foil type VT	coupling foil type TF

for further data see Technical specification TS_G8xx-transducersVx-xxx_Leu

Damping material

	damping mat		damping coat
item number	992080-11	992080-10	992080-13
type	E30R4	E30R3	

for further data see Technical specification TS_G8xx-transducersVx-xxx_Leu

Connection systems

connection system T1		
connection with extension cable	direct connection	transducers technical type
<p>JB06</p>	<p>transmitter</p>	<p>****53</p>
<p>JB01</p>	<p>transmitter</p>	<p>****6*</p>
<p>JB01</p>	<p>transmitter</p>	<p>****L1*</p>
<p>terminal board for junction box (junction box by customer)</p>	<p>transmitter</p>	<p>****62</p>

for further data see Technical specification TS_G8xx-transducersVx-xxx_Leu

Temperature Probes

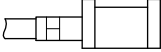
PT12N (item number: 770415-6)	PT12N (item number: 770415-7)
<ul style="list-style-type: none"> • Pt100 • clamp-on • ATEX zone 0/1 (intrinsic safety) • for 831-*B* 	<ul style="list-style-type: none"> • Pt100 • clamp-on • ATEX zone 1 • for 831-*NN
	

see Technical specification TS_PTVx-xXX

For more information: **Emerson.com**

© 2025 Emerson. All rights reserved.

Emerson Terms and Conditions of Sale are available upon request.

The Emerson logo is a trademark and service mark of Emerson Electric Co. Flexim is a mark of one of the Emerson family of companies. All other marks are the property of their respective owners.