

Series 71
Unique PCB mounting system.

<https://eao.com/71>



71 Information about the Series

Key advantages

- Unique PCB mounting
- A variety of switching functions
- Modular design and flush mounting
- IP65 front protection

Typical application areas

- Machinery and control systems
- Control cabinet engineering
- Special vehicles
- Conveyor systems
- Process automation
- Plus many other applications

Functions

- Pushbutton
- Illuminated pushbutton
- Mushroom-head pushbutton
- Selector switch
- Keylock switch
- Indicator

Design

- Flush

IP front protection

- IP65

Rating

- 250 VAC (3 A)

Mounting cut-outs

- Ø 22.3 mm
- Square
- Rectangular
- PCB

Terminal

- PCB

Lens Material

- Aluminium
- Plastic

Markings

- Engraving
- Laser marking
- Hot stamping
- Film insert / marking plate
- Screen print

Approvals

- CQC

Conformities

- CE
- UKCA
- 2011/65/EU (RoHS)



Flush design		
Pushbutton round	818	01
Illuminated pushbutton square	819	02
Illuminated pushbutton rectangular	820	03
Illuminated pushbutton round	821	04
Mushroom-head pushbutton	822	09
Selector switch 2 positions square	823	14
Selector switch 2 positions round	824	17
Selector switch 3 positions square	825	18
Selector switch 3 positions round	826	19
Keylock switch 2 positions square	827	22
Keylock switch 2 positions rectangular	829	31
Keylock switch 2 positions round	831	41
Keylock switch 3 positions square	833	45
Keylock switch 3 positions rectangular	835	51
Keylock switch 3 positions round	837	56
Indicator square	839	57
Indicator rectangular	840	61
Indicator round	841	70
Components	842	71
Accessories	853	82
Technical data	857	84
Marking	859	92
Application guidelines	860	96

71 Flush design

Pushbutton round, IP65



Product can differ from the current configuration.

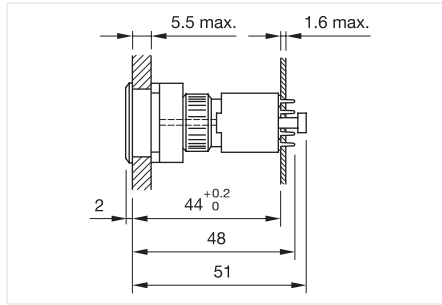

Dimensions [mm]



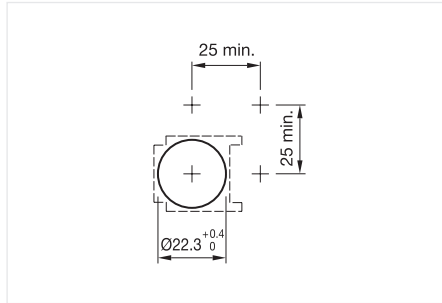

General information

- Pitch of the front plate mounting holes must agree with the printed circuit board holes $\varnothing 3.5$ mm
- For front dimension $\varnothing 25$ mm

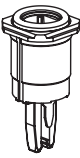

Mounting cut-outs [mm]

Equipment consisting of (schematic overview)

	Lens	Page 842
	Actuator	
	Front bezel set	Page 845
	Fixing nut	
	Switching element	Page 848
	Interlocking pin	

Each Part Number listed below includes all the black components shown in the 3D-drawing.



To obtain a complete unit, please select the red components from the pages shown.



Actuator, Front dimension 25 mm







Switching action	Part No.	Wiring diagram
Momentary	71-611.0	72
Maintained	71-612.0	73

Wiring diagrams

	
Wiring diagram 72	Wiring diagram 73

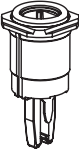
Illuminated pushbutton square, IP65

Equipment consisting of (schematic overview)

-  Lens Page 842
-  LED Page 846
-  Actuator
-  Front bezel set Page 845
-  Fixing nut
-  Switching element Page 848
-  Interlocking pin

Each Part Number listed below includes all the black components shown in the 3D-drawing.

To obtain a complete unit, please select the red components from the pages shown.

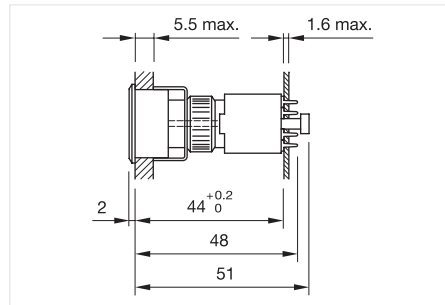

Dimensions [mm]



Product can differ from the current configuration.

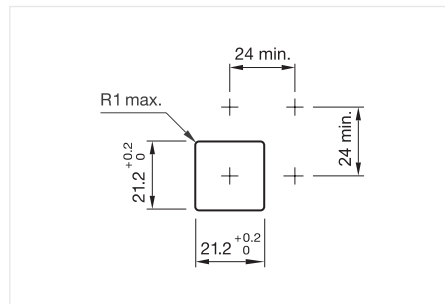

Mounting cut-outs [mm]

General information

- Pitch of the front plate mounting holes must agree with the printed circuit board holes \varnothing 3.5 mm



Actuator, Front dimension 24 mm x 24 mm

Switching action	Part No.	Wiring diagram
Momentary	71-611.0	72
Maintained	71-612.0	73

Wiring diagrams

Wiring diagram 72	Wiring diagram 73

71 Flush design

Illuminated pushbutton rectangular, IP65

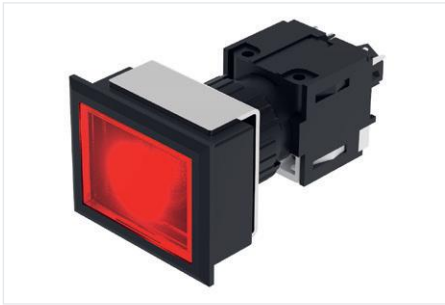

Product can differ from the current configuration.

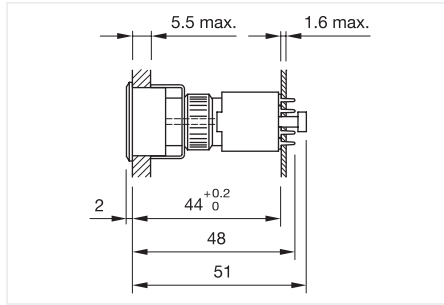

Dimensions [mm]

General information

- Pitch of the front plate mounting holes must agree with the printed circuit board holes $\varnothing 3.5$ mm
- For front dimension 24 mm x 30 mm

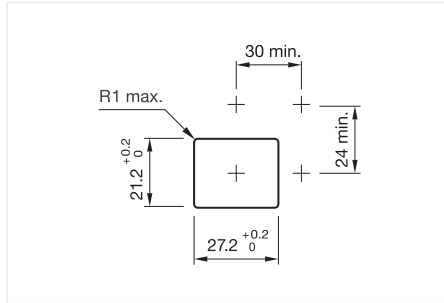

Mounting cut-outs [mm]

Equipment consisting of (schematic overview)

	Lens	Page 842
	LED	Page 846
	Actuator	
	Front bezel set	Page 845
	Fixing nut	
	Switching element	Page 848
	Interlocking pin	

Each Part Number listed below includes all the black components shown in the 3D-drawing.

To obtain a complete unit, please select the red components from the pages shown.



Actuator, Front dimension 30 mm x 24 mm







Switching action	Part No.	Wiring diagram
Momentary	71-611.0	72
Maintained	71-612.0	73

Wiring diagrams

Wiring diagram 72	Wiring diagram 73

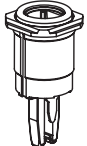
Illuminated pushbutton round, IP65

Equipment consisting of (schematic overview)

	Lens	Page 842
	LED	Page 846
	Actuator	
	Front bezel set	Page 845
	Fixing nut	
	Switching element	Page 848
	Interlocking pin	

Each Part Number listed below includes all the black components shown in the 3D-drawing.

To obtain a complete unit, please select the red components from the pages shown.

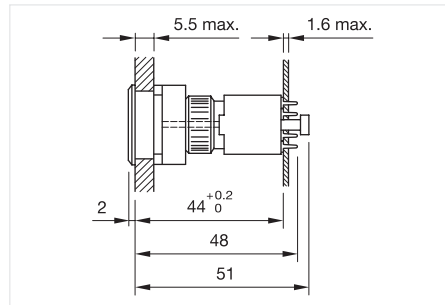

Dimensions [mm]



Product can differ from the current configuration.

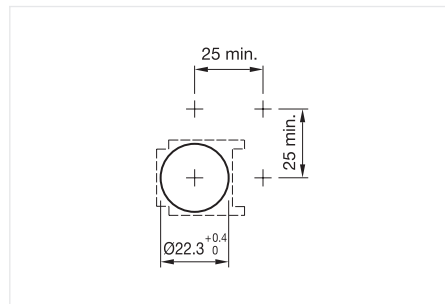

Mounting cut-outs [mm]

General information



- Pitch of the front plate mounting holes must agree with the printed circuit board holes Ø 3.5 mm
- For front dimension Ø 25 mm



Actuator, Front dimension Ø 25 mm

Switching action	Part No.	Wiring diagram
Momentary	71-611.0	72
Maintained	71-612.0	73

Wiring diagrams

	
Wiring diagram 72	Wiring diagram 73

71 Flush design

Mushroom-head pushbutton, IP65



Product can differ from the current configuration.

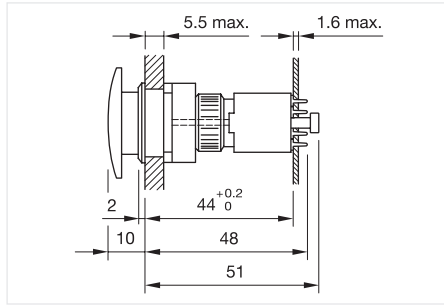

Dimensions [mm]



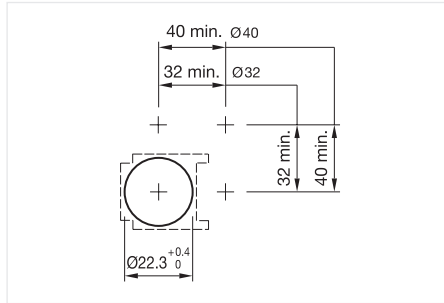

General information

- Pitch of the front plate mounting holes must agree with the printed circuit board holes $\varnothing 3.5$ mm

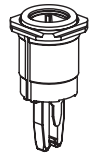

Mounting cut-outs [mm]

Equipment consisting of (schematic overview)

	Lens	Page 842
	Actuator	
	Front bezel set	Page 845
	Fixing nut	
	Switching element	Page 848
	Interlocking pin	

Each Part Number listed below includes all the black components shown in the 3D-drawing.

To obtain a complete unit, please select the red components from the pages shown.



Actuator, Front dimension $\varnothing 32$ mm







Switching action	Part No.	Wiring diagram
Momentary	71-611.0	72
Maintained	71-612.0	73

Wiring diagrams

E---	E~--
Wiring diagram 72	Wiring diagram 73

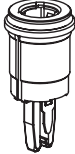
Selector switch 2 positions square, IP65

Equipment consisting of (schematic overview)

-  Lever Page 844
-  LED Page 846
-  Actuator
-  Front bezel set Page 845
-  Fixing nut
-  Switching element Page 848
-  Interlocking pin

Each Part Number listed below includes all the black components shown in the 3D-drawing.

To obtain a complete unit, please select the red components from the pages shown.

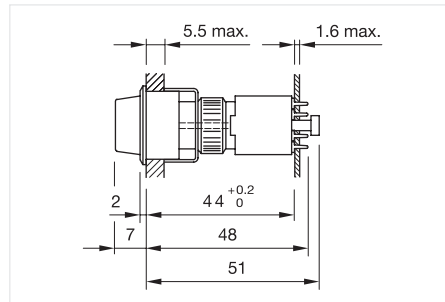

Dimensions [mm]



Product can differ from the current configuration.

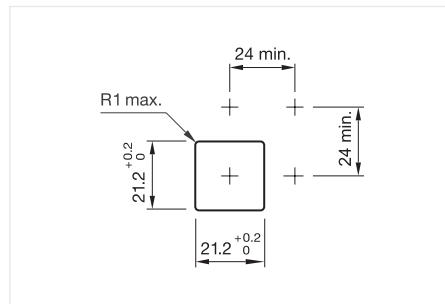

Mounting cut-outs [mm]

General information

- Illuminative

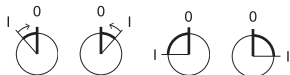

Actuator, Front dimension 24 mm x 24 mm

Switching action	Switching angle	Part No.	Wiring diagram
Momentary - Rest	42° left	71-641.0	334
Rest - Momentary	42° right	71-641.0A	84
Maintained - Rest	90° left	71-642.0	85
Rest - Maintained	90° right	71-642.0A	85

Wiring diagrams

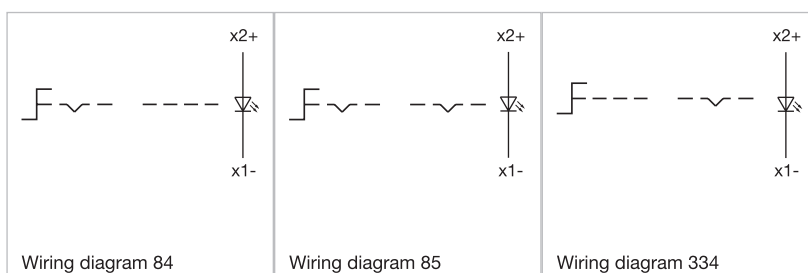

71 Flush design

Selector switch 2 positions round, IP65



Product can differ from the current configuration.

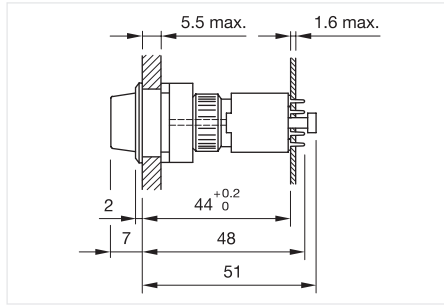





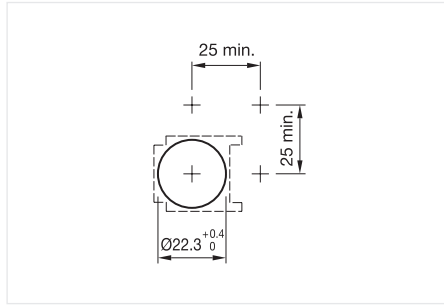

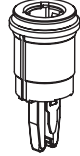

General information

- Illuminative



Equipment consisting of (schematic overview)

-  Lever Page 844
-  LED Page 846
-  Actuator
-  Front bezel set Page 845
-  Anti-twist ring
-  Fixing nut
-  Switching element Page 848
-  Interlocking pin

Each Part Number listed below includes all the black components shown in the 3D-drawing.

To obtain a complete unit, please select the red components from the pages shown.

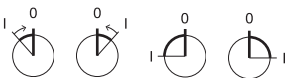

Actuator, Front dimension Ø 25 mm





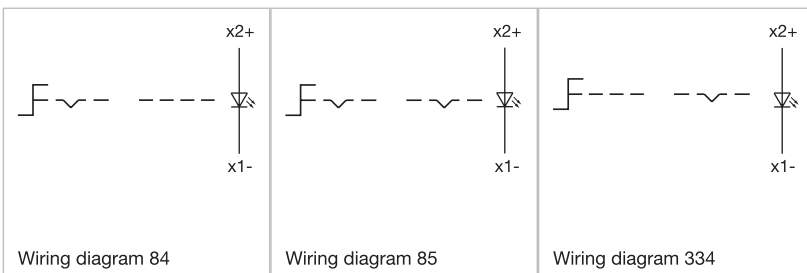

Switching action	Switching angle	Part No.	Wiring diagram
Momentary - Rest	42° left	71-641.0	334
Rest - Momentary	42° right	71-641.0A	84
Maintained - Rest	90° left	71-642.0	85
Rest - Maintained	90° right	71-642.0A	85

Wiring diagrams

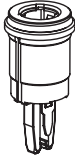

Selector switch 3 positions square, IP65

Equipment consisting of (schematic overview)

-  Lever Page 844
-  LED Page 846
-  Actuator
-  Front bezel set Page 845
-  Fixing nut
-  Switching element Page 848
-  Interlocking pin

Each Part Number listed below includes all the black components shown in the 3D-drawing.

To obtain a complete unit, please select the red components from the pages shown.

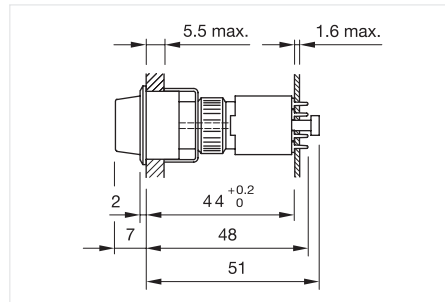

Dimensions [mm]



Product can differ from the current configuration.

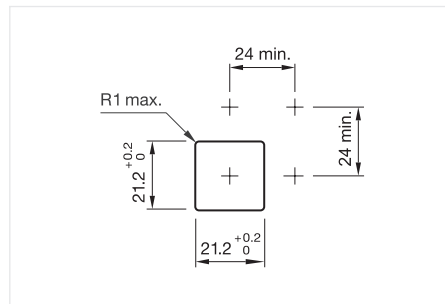

Mounting cut-outs [mm]

General information

- Illuminative

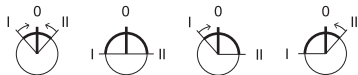

Actuator, Front dimension 24 mm x 24 mm

Switching action	Switching angle	Part No.	Wiring diagram
Momentary - Rest - Momentary	42° left / 42° right	71-651.0	89
Maintained - Rest - Maintained	90° left / 90° right	71-652.0	90
Momentary - Rest - Maintained	42° left / 90° right	71-656.0	88
Maintained - Rest - Momentary	90° left / 42° right	71-658.0	89

Wiring diagrams

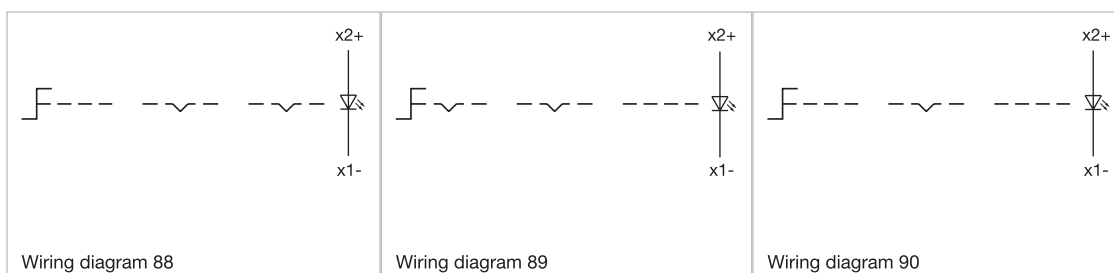

71 Flush design

Selector switch 3 positions round, IP65



Product can differ from the current configuration.

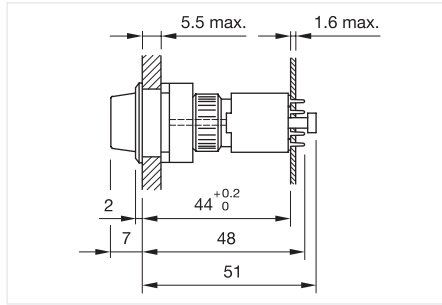

General information

- Illuminative

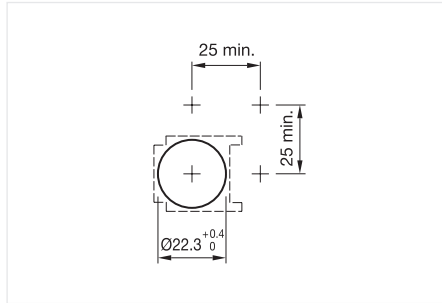

Equipment consisting of (schematic overview)

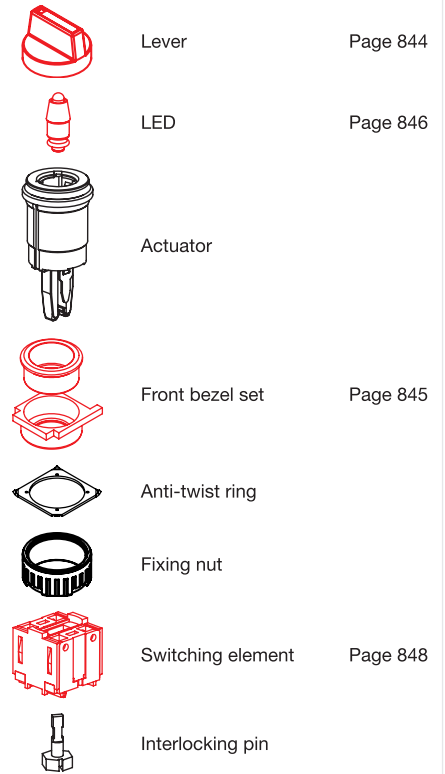

Each Part Number listed below includes all the black components shown in the 3D-drawing.

To obtain a complete unit, please select the red components from the pages shown.

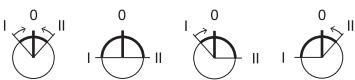

Actuator, Front dimension Ø 25 mm





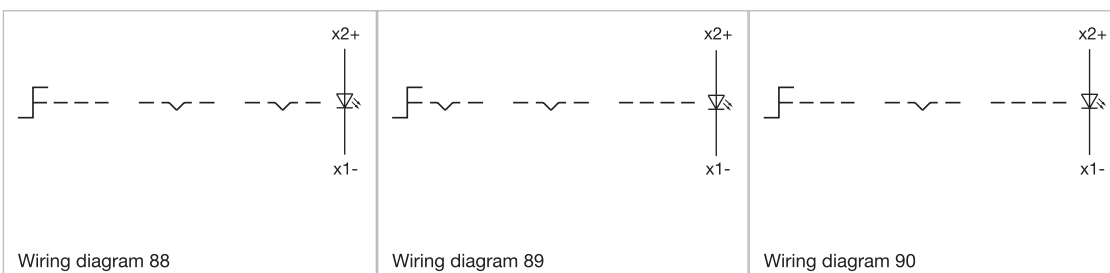

Switching action	Switching angle	Part No.	Wiring diagram
Momentary - Rest - Momentary	42° left / 42° right	71-651.0	89
Maintained - Rest - Maintained	90° left / 90° right	71-652.0	90
Momentary - Rest - Maintained	42° left / 90° right	71-656.0	88
Maintained - Rest - Momentary	90° left / 42° right	71-658.0	89

Wiring diagrams

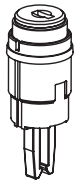

Keylock switch 2 positions square, IP65

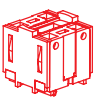
Equipment consisting of (schematic overview)

-  Key
-  Keylock front bezel Page 844
-  Actuator
-  Front bezel set Page 845
-  Fixing nut
-  Switching element Page 848
-  Interlocking pin

Each Part Number listed below includes all the black components shown in the 3D-drawing.

To obtain a complete unit, please select the red components from the pages shown.

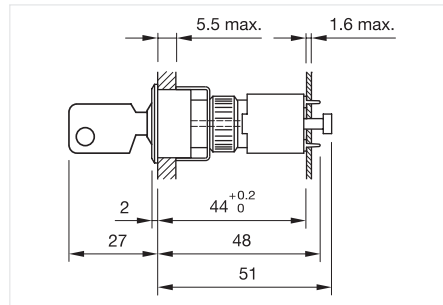

Dimensions [mm]



Product can differ from the current configuration.

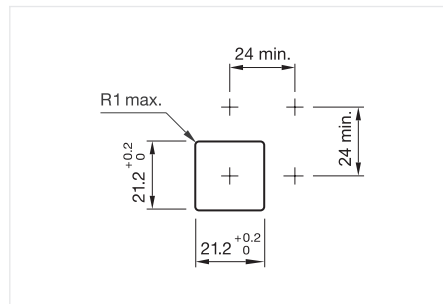

Mounting cut-outs [mm]

General information

- Standard lock: DOM 311

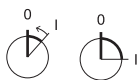

Actuator, Front dimension 24 mm x 24 mm

Switching action	Switching angle	Part No.	Wiring diagram
Rest (a) - Momentary	42° right	71-621.0/D	78
Rest (a) - Maintained	90° right	71-622.0/D	79
Rest - Maintained (a)	90° right	71-623.0/D	79
Rest (a) - Maintained (a)	90° right	71-624.0/D	79

a = Key remove

71 Flush design

Wiring diagrams

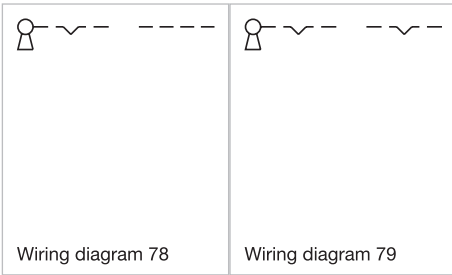

EAO Downloads.
www.eao.com/downloads
EAO creates possibilities. Since 1947.



[On our website you can download technical data, assembly instructions, catalogs, brochures and much more.](http://www.eao.com/downloads)

Keylock switch 2 positions rectangular, IP65

Equipment consisting of (schematic overview)

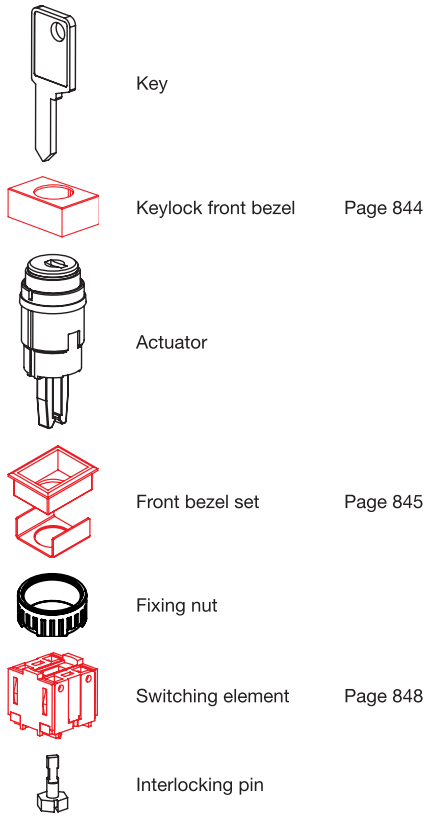

Each Part Number listed below includes all the black components shown in the 3D-drawing.

To obtain a complete unit, please select the red components from the pages shown.

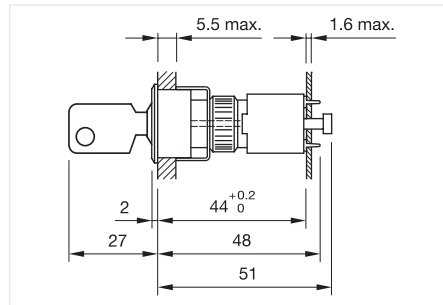

Dimensions [mm]



Product can differ from the current configuration.

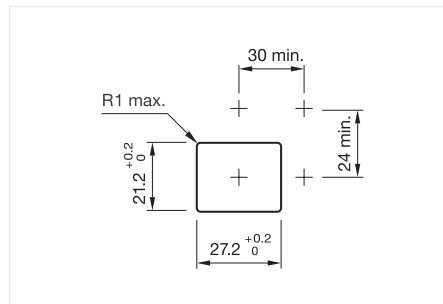

Mounting cut-outs [mm]

General information

- Standard lock: DOM 311

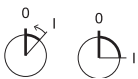

Actuator, Front dimension 30 mm x 24 mm

Switching action	Switching angle	Part No.	Wiring diagram
Rest (a) - Momentary	42° right	71-621.0/D	78
Rest (a) - Maintained	90° right	71-622.0/D	79
Rest - Maintained (a)	90° right	71-623.0/D	79
Rest (a) - Maintained (a)	90° right	71-624.0/D	79

a = Key remove





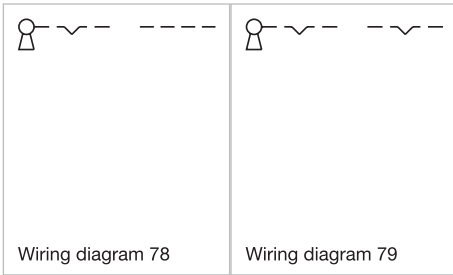



71 Flush design

Wiring diagrams

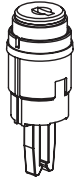

Keylock switch 2 positions round, IP65

Equipment consisting of (schematic overview)

-  Key
-  Keylock front bezel Page 845
-  Actuator
-  Front bezel set Page 845
-  Anti-twist ring
-  Fixing nut
-  Switching element Page 848
-  Interlocking pin

Each Part Number listed below includes all the black components shown in the 3D-drawing.

To obtain a complete unit, please select the red components from the pages shown.

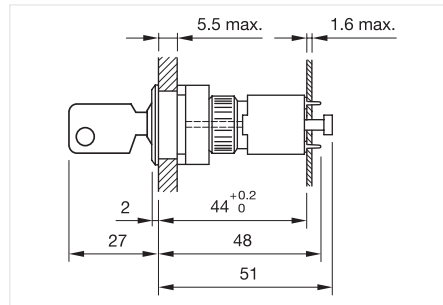

Dimensions [mm]

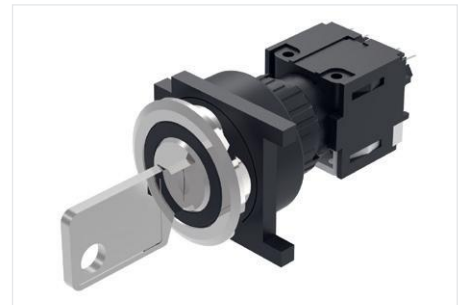

Product can differ from the current configuration.

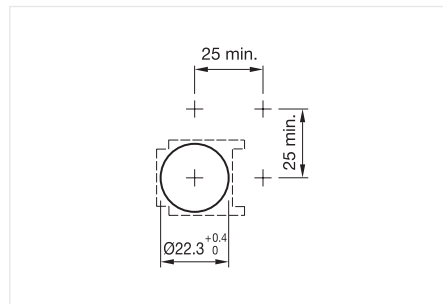

Mounting cut-outs [mm]

General information

- Standard lock: DOM 311



Actuator, Front dimension Ø 25 mm

Switching action	Switching angle	Part No.	Wiring diagram
Rest (a) - Momentary	42° right	71-621.0/D	78
Rest (a) - Maintained	90° right	71-622.0/D	79
Rest - Maintained (a)	90° right	71-623.0/D	79
Rest (a) - Maintained (a)	90° right	71-624.0/D	79

a = Key remove

71 Flush design

Wiring diagrams

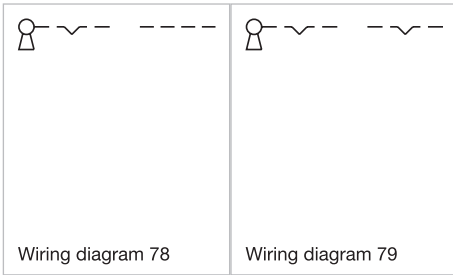

Keylock switch 3 positions square, IP65

Equipment consisting of (schematic overview)

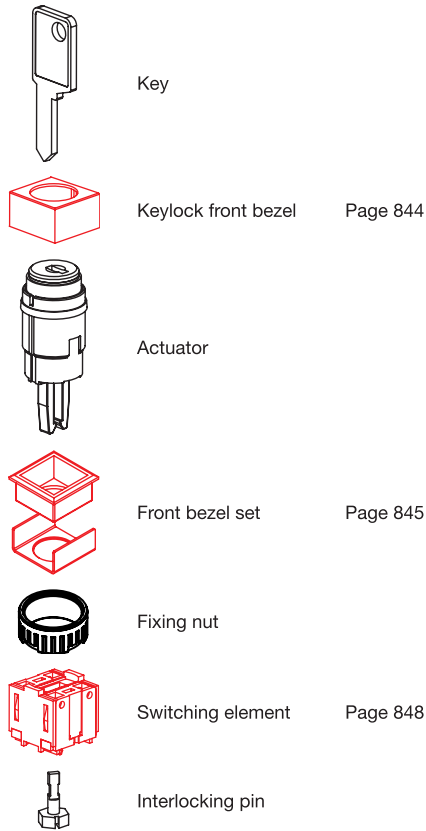

Each Part Number listed below includes all the black components shown in the 3D-drawing.

To obtain a complete unit, please select the red components from the pages shown.

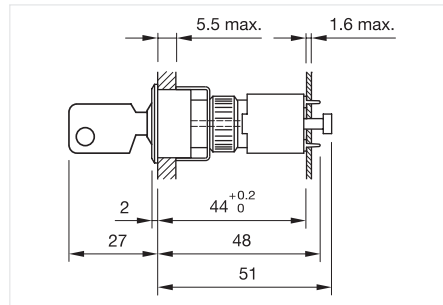

Dimensions [mm]

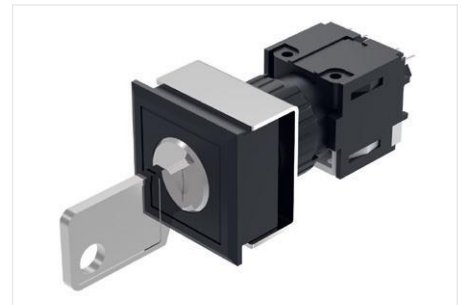

Product can differ from the current configuration.

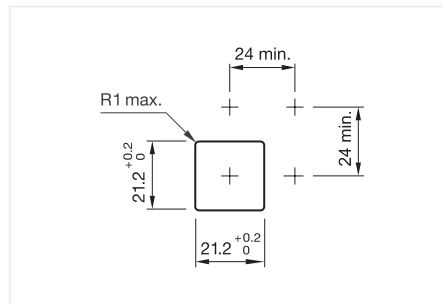

Mounting cut-outs [mm]

General information

- Standard lock: DOM 311
- For front dimension 24 mm x 24 mm



Actuator, Front dimension 24 mm x 24 mm

Switching action	Switching angle	Part No.	Wiring diagram
Momentary - Rest (a) - Momentary	42° left / 42° right	71-631.0/D	82
Maintained - Rest (a) - Maintained	90° left / 90° right	71-632.0/D	83
Maintained - Rest - Maintained (a)	90° left / 90° right	71-633.0/D	83
Maintained (a) - Rest - Maintained (a)	90° left / 90° right	71-634.0/D	83
Maintained (a) - Rest (a) - Maintained (a)	90° left / 90° right	71-635.0/D	83
Maintained - Rest (a) - Momentary	90° left / 42° right	71-636.0/D	81
Maintained (a) - Rest (a) - Momentary	90° left / 42° right	71-637.0/D	81
Momentary - Rest (a) - Maintained	42° left / 90° right	71-638.0/D	80
Maintained (a) - Rest (a) - Momentary	90° left / 42° right	71-639.0/D	80

a = Key remove

71 Flush design

Wiring diagrams

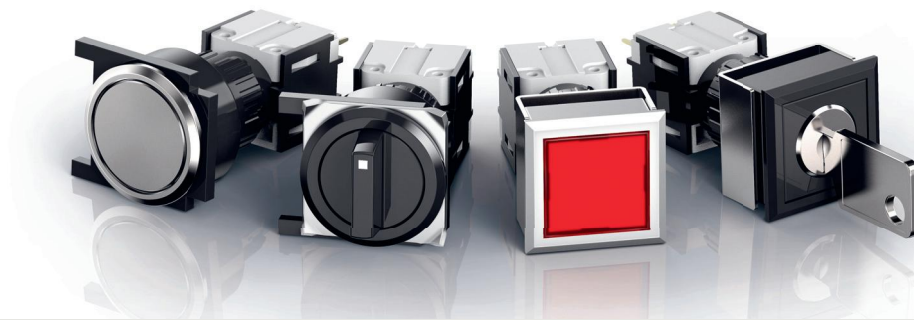
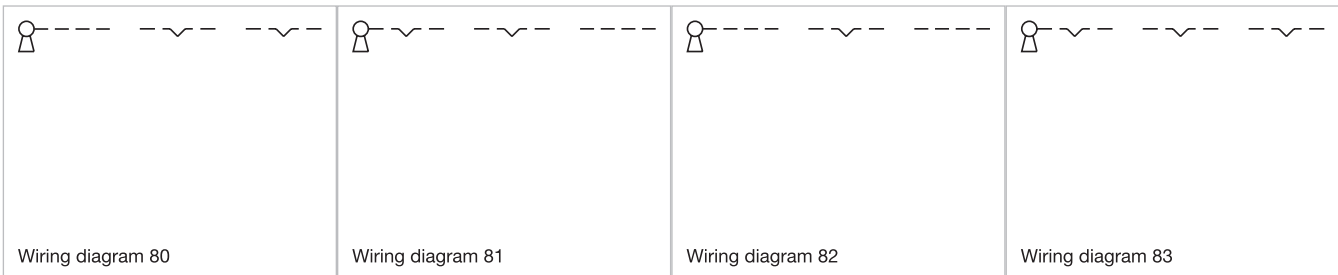

Unique PCB mounting system. *The versatile Series 71.*

A special PCB technology enables the Series 71 to provide versatile opportunities.

- Unique PCB mounting system
- A variety of switching functions
- Modular design and flush mounting
- IP65 front protection

Keylock switch 3 positions rectangular, IP65

Equipment consisting of (schematic overview)

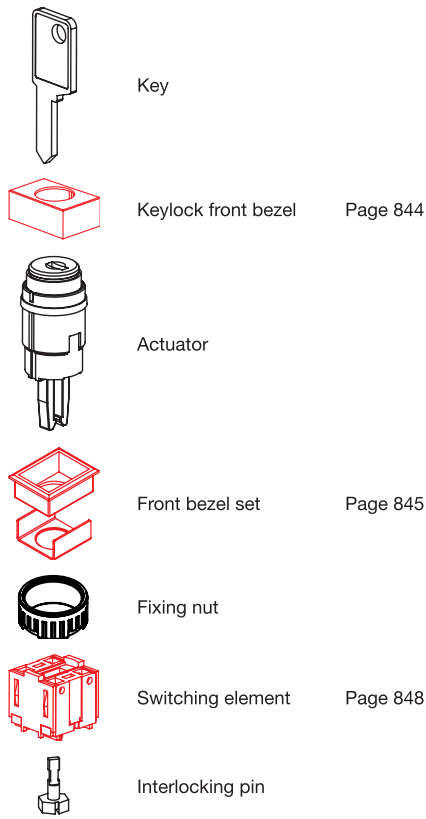

Each Part Number listed below includes all the black components shown in the 3D-drawing.

To obtain a complete unit, please select the red components from the pages shown.

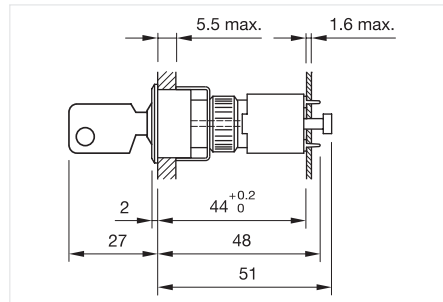

Dimensions [mm]



Product can differ from the current configuration.

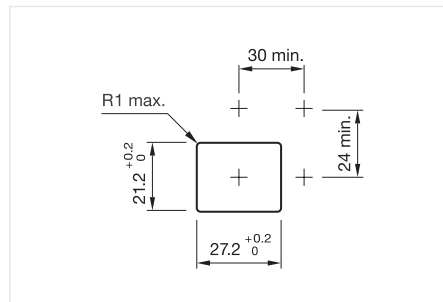

Mounting cut-outs [mm]

General information

- Standard lock: DOM 311



Actuator, Front dimension 30 mm x 24 mm

Switching action	Switching angle	Part No.	Wiring diagram
Momentary - Rest (a) - Momentary	42° left / 42° right	71-631.0/D	82
Maintained - Rest (a) - Maintained	90° left / 90° right	71-632.0/D	83
Maintained - Rest - Maintained (a)	90° left / 90° right	71-633.0/D	83
Maintained (a) - Rest - Maintained (a)	90° left / 90° right	71-634.0/D	83
Maintained (a) - Rest (a) - Maintained (a)	90° left / 90° right	71-635.0/D	83
Maintained - Rest (a) - Momentary	90° left / 42° right	71-636.0/D	81
Maintained (a) - Rest (a) - Momentary	90° left / 42° right	71-637.0/D	81
Momentary - Rest (a) - Maintained	42° left / 90° right	71-638.0/D	80
Maintained (a) - Rest (a) - Momentary	90° left / 42° right	71-639.0/D	80

a = Key remove





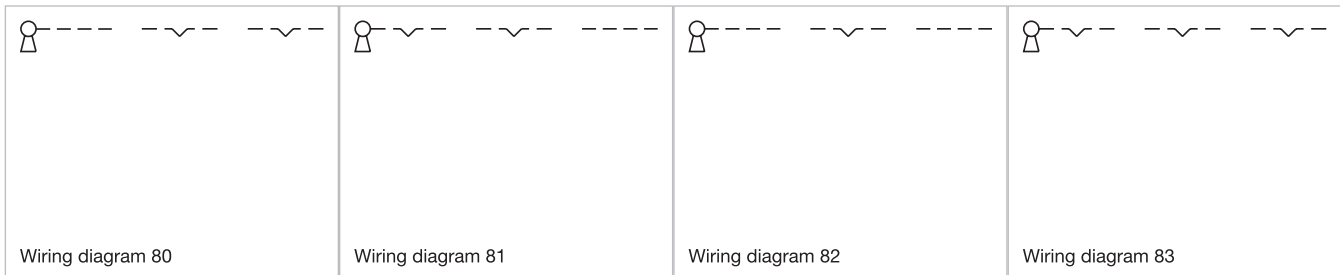



71 Flush design

Wiring diagrams

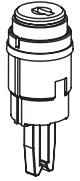

Keylock switch 3 positions round, IP65

Equipment consisting of (schematic overview)

-  Key
-  Keylock front bezel Page 845
-  Actuator
-  Front bezel set Page 845
-  Anti-twist ring
-  Fixing nut
-  Switching element Page 848
-  Interlocking pin

Each Part Number listed below includes all the black components shown in the 3D-drawing.

To obtain a complete unit, please select the red components from the pages shown.

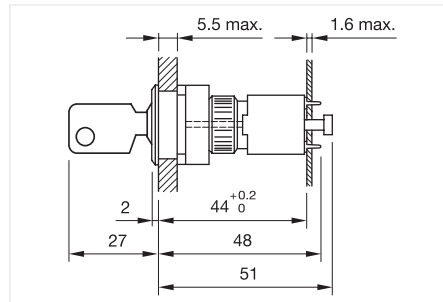

Dimensions [mm]

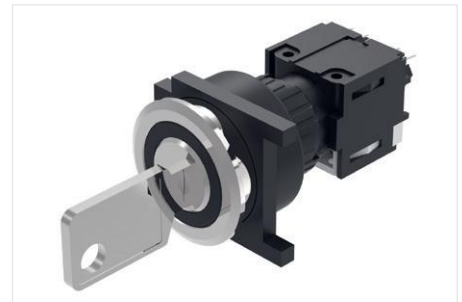

Product can differ from the current configuration.

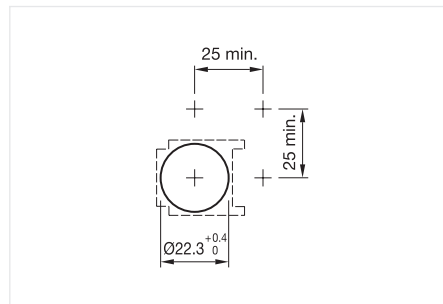

Mounting cut-outs [mm]

General information

- Standard lock: DOM 311



Actuator, Front dimension Ø 25 mm

Switching action	Switching angle	Part No.	Wiring diagram
Momentary - Rest (a) - Momentary	42° left / 42° right	71-631.0/D	82
Maintained - Rest (a) - Maintained	90° left / 90° right	71-632.0/D	83
Maintained - Rest - Maintained (a)	90° left / 90° right	71-633.0/D	83
Maintained (a) - Rest - Maintained (a)	90° left / 90° right	71-634.0/D	83
Maintained (a) - Rest (a) - Maintained (a)	90° left / 90° right	71-635.0/D	83
Maintained - Rest (a) - Momentary	90° left / 42° right	71-636.0/D	81
Maintained (a) - Rest (a) - Momentary	90° left / 42° right	71-637.0/D	81
Momentary - Rest (a) - Maintained	42° left / 90° right	71-638.0/D	80
Maintained (a) - Rest (a) - Momentary	90° left / 42° right	71-639.0/D	80

a = Key remove

71 Flush design

Wiring diagrams

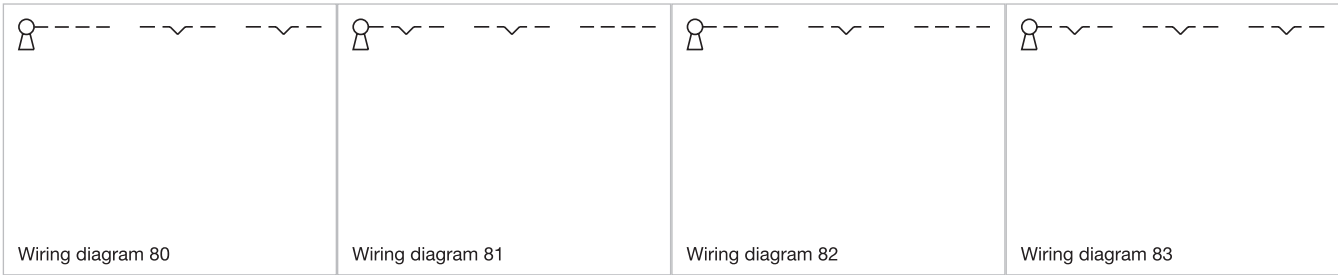







EAO Downloads.
www.eao.com/downloads
EAO creates possibilities. Since 1947.

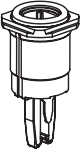

[On our website you can download technical data, assembly instructions, catalogs, brochures and much more.](http://www.eao.com/downloads)

Indicator square, IP65

Equipment consisting of (schematic overview)

-  Lens Page 842
-  LED Page 846
-  Actuator
-  Front bezel set Page 845
-  Fixing nut
-  Lamp element Page 850
-  Interlocking pin

Each Part Number listed below includes all the black components shown in the 3D-drawing.

To obtain a complete unit, please select the red components from the pages shown.

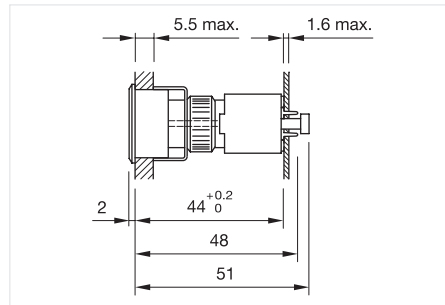

Dimensions [mm]



Product can differ from the current configuration.

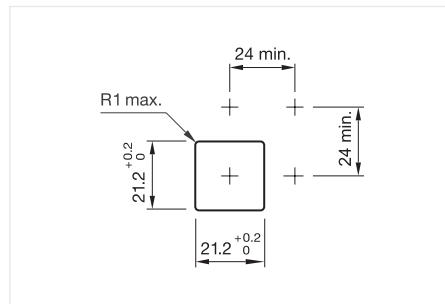

Mounting cut-outs [mm]

General information

- Pitch of the front plate mounting holes must agree with the printed circuit board holes \varnothing 3.5 mm



Actuator, Front dimension 24 mm x 24 mm

Material	Part No.	Wiring diagram
plastic	71-600.0	68

Wiring diagrams

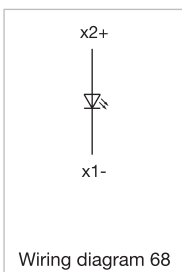

71 Flush design

Indicator rectangular, IP65

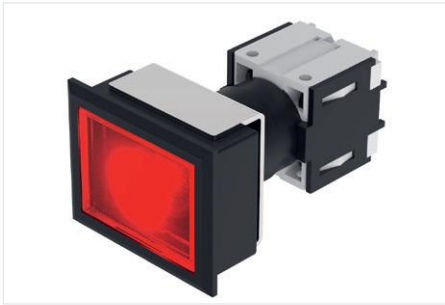

Product can differ from the current configuration.

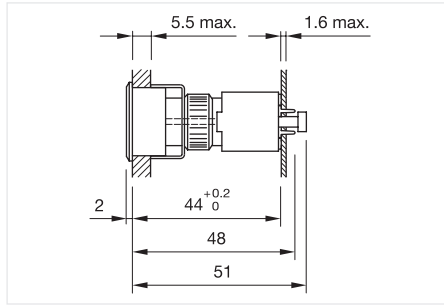





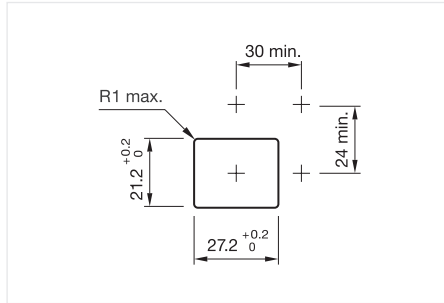

General information

- Pitch of the front plate mounting holes must agree with the printed circuit board holes \varnothing 3.5 mm

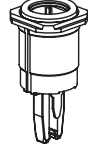

Equipment consisting of (schematic overview)

	Lens	Page 842
	LED	Page 846
	Actuator	
	Front bezel set	Page 845
	Fixing nut	
	Lamp element	Page 850
	Interlocking pin	

Each Part Number listed below includes all the black components shown in the 3D-drawing.

To obtain a complete unit, please select the red components from the pages shown.



Actuator, Front dimension 30 mm x 24 mm





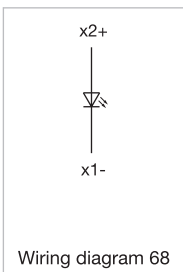

Material	Part No.	Wiring diagram
plastic	71-600.0	68

Wiring diagrams

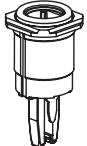

Indicator round, IP65

Equipment consisting of (schematic overview)

	Lens	Page 842
	LED	Page 846
	Actuator	
	Front bezel set	Page 845
	Fixing nut	
	Lamp element	Page 850
	Interlocking pin	

Each Part Number listed below includes all the black components shown in the 3D-drawing.

To obtain a complete unit, please select the red components from the pages shown.

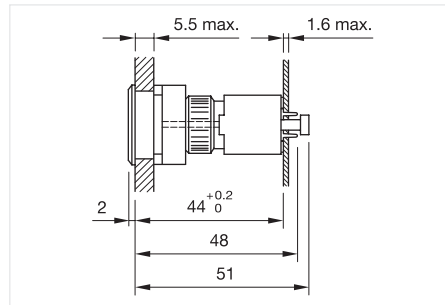

Dimensions [mm]



Product can differ from the current configuration.

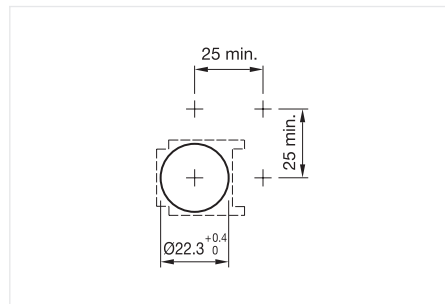

Mounting cut-outs [mm]

General information

- Pitch of the front plate mounting holes must agree with the printed circuit board holes $\varnothing 3.5$ mm



Actuator, Front dimension $\varnothing 25$ mm

Material	Part No.	Wiring diagram
plastic	71-600.0	68

Wiring diagrams

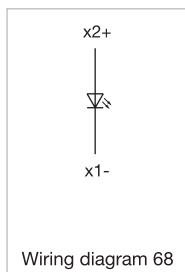

71 Components



Lens square, flush design

Lens material	Lens colour	Lens optics	Lens shape	Lens illumination	Dimensions	Part No.
Plastic	Smokey black	transparent	flush	illuminative	18 mm x 18 mm	61-9671.1
	Red	transparent	flush	illuminative	18 mm x 18 mm	61-9671.2
	Orange	transparent	flush	illuminative	18 mm x 18 mm	61-9671.3
	Yellow	transparent	flush	illuminative	18 mm x 18 mm	61-9671.4
	Green	transparent	flush	illuminative	18 mm x 18 mm	61-9671.5
	Blue	transparent	flush	illuminative	18 mm x 18 mm	61-9671.6
	Colourless	transparent	flush	illuminative	18 mm x 18 mm	61-9671.7
	Black	opaque	flush	non illuminative	18 mm x 18 mm	61-9771.0
	White	translucent	flush	non illuminative	18 mm x 18 mm	61-9771.9



Lens rectangular, flush design

Lens material	Lens colour	Lens optics	Lens shape	Lens illumination	Dimensions	Part No.
Plastic	Smokey black	transparent	flush	illuminative	18 mm x 24 mm	61-9681.1
	Red	transparent	flush	illuminative	18 mm x 24 mm	61-9681.2
	Orange	transparent	flush	illuminative	18 mm x 24 mm	61-9681.3
	Yellow	transparent	flush	illuminative	18 mm x 24 mm	61-9681.4
	Green	transparent	flush	illuminative	18 mm x 24 mm	61-9681.5
	Blue	transparent	flush	illuminative	18 mm x 24 mm	61-9681.6
	Colourless	transparent	flush	illuminative	18 mm x 24 mm	61-9681.7
	Black	opaque	flush	non illuminative	18 mm x 24 mm	61-9781.0
	White	translucent	flush	non illuminative	18 mm x 24 mm	61-9781.9



Lens round, flush design

Lens material	Lens colour	Lens optics	Lens shape	Lens illumination	Dimensions	Part No.
Plastic	Smokey black	transparent	flush	illuminative	Ø 19,7 mm	61-9642.1
	Red	transparent	flush	illuminative	Ø 19,7 mm	61-9642.2
	Orange	transparent	flush	illuminative	Ø 19,7 mm	61-9642.3
	Yellow	transparent	flush	illuminative	Ø 19,7 mm	61-9642.4
	Green	transparent	flush	illuminative	Ø 19,7 mm	61-9642.5
	Blue	transparent	flush	illuminative	Ø 19,7 mm	61-9642.6
	Colourless	transparent	flush	illuminative	Ø 19,7 mm	61-9642.7



Lens plastic with symbol

Lens material	Lens colour	Lens optics	Lens shape	Lens illumination	Symbol	Dimensions	Part No.
Plastic	Red	transparent	flush	illuminative	Ring	Ø 19,7 mm	61-9643.201
	Orange	transparent	flush	illuminative	Ring	Ø 19,7 mm	61-9643.301
	Yellow	transparent	flush	illuminative	Ring	Ø 19,7 mm	61-9643.401
	Green	transparent	flush	illuminative	Ring	Ø 19,7 mm	61-9643.501
	Blue	transparent	flush	illuminative	Ring	Ø 19,7 mm	61-9643.601
	Colourless	transparent	flush	illuminative	Ring	Ø 19,7 mm	61-9643.701
	Red	transparent	flush	illuminative	ON/OFF	Ø 19,7 mm	61-9643.202
	Green	transparent	flush	illuminative	ON/OFF	Ø 19,7 mm	61-9643.502
	Blue	transparent	flush	illuminative	ON/OFF	Ø 19,7 mm	61-9643.602
	Colourless	transparent	flush	illuminative	ON/OFF	Ø 19,7 mm	61-9643.702
	Red	transparent	flush	illuminative	Standby	Ø 19,7 mm	61-9643.203
	Green	transparent	flush	illuminative	Standby	Ø 19,7 mm	61-9643.503
	Blue	transparent	flush	illuminative	Standby	Ø 19,7 mm	61-9643.603
	Colourless	transparent	flush	illuminative	Standby	Ø 19,7 mm	61-9643.703

Additional information

- The silvery coat is being applied on the lens (screen print) with an additional protective lacquer. Further information see Technical data



Lens metal

Lens material	Lens colour	Lens optics	Lens shape	Lens illumination	Dimensions	Part No.
Aluminium	Black	opaque	flush	non illuminative	Ø 19,7 mm	61-9841.0
	Red	opaque	flush	non illuminative	Ø 19,7 mm	61-9841.2
	Gold	opaque	flush	non illuminative	Ø 19,7 mm	61-9841.4
	Olive green	opaque	flush	non illuminative	Ø 19,7 mm	61-9841.5
	Blue	opaque	flush	non illuminative	Ø 19,7 mm	61-9841.6
	Nature	opaque	flush	non illuminative	Ø 19,7 mm	61-9841.8
	Black	opaque	convex	non illuminative	Ø 19,7 mm	61-9842.0
	Red	opaque	convex	non illuminative	Ø 19,7 mm	61-9842.2
	Olive green	opaque	convex	non illuminative	Ø 19,7 mm	61-9842.5
	Nature	opaque	convex	non illuminative	Ø 19,7 mm	61-9842.8

Additional information

- The colour of anodised aluminium parts can vary due to technical production reasons



Lens metal with spot

Lens material	Lens colour	Lens optics	Lens shape	Lens illumination	Dimensions	Part No.
Aluminium	Black	opaque	flush	illuminative	Ø 19,7 mm	61-9841.0A
	Red	opaque	flush	illuminative	Ø 19,7 mm	61-9841.2A
	Gold	opaque	flush	illuminative	Ø 19,7 mm	61-9841.4A
	Olive green	opaque	flush	illuminative	Ø 19,7 mm	61-9841.5A
	Blue	opaque	flush	illuminative	Ø 19,7 mm	61-9841.6A
	Nature	opaque	flush	illuminative	Ø 19,7 mm	61-9841.8A

Additional information

- The colour of anodised aluminium parts can vary due to technical production reasons

71 Components



Mushroom-head cap

Lens material	Lens colour	Lens optics	Lens shape	Lens illumination	Part No.
Plastic	Black	opaque	flush	non illuminative	61-9593.0
	Red	opaque	flush	non illuminative	61-9593.2



Keylock front bezel

Material	Colour	Dimensions	Part No.
plastic	Black	18 mm x 18 mm	61-9220.0
	Black	24 mm x 18 mm	61-9230.0
	Black	Ø 18 mm	61-9210.0



Lever flush design

Lever material	Lever colour	Lever illumination	Lever bar colour	Part No.
plastic	Black	illuminative	Red	61-9028.20
	Black	illuminative	Yellow	61-9028.40
	Black	illuminative	Green	61-9028.50
	Black	illuminative	Blue	61-9028.60
	Grey	illuminative	Red	61-9029.20
	Grey	illuminative	Orange	61-9029.30
	Grey	illuminative	Yellow	61-9029.40
	Black	non illuminative		61-9028.0
	Black	illuminative	White	61-9028.9
	Grey	non illuminative		61-9029.8

Additional information

- With bar and marking dot



Marking plate

Marking plate material	Marking plate colour	Marking plate optics	Marking plate illumination	Part No.
Plastic	Colourless	transparent	illuminative	61-9707.7

Additional information

- Can be hot stamped



Front bezel set flush design

Product attributes	Front bezel material	Front bezel colour	Front bezel surface	Mounting cut-out	Dimensions	Part No.
For indicator illuminated pushbutton and keylock switch	Plastic	Black		21 mm x 21 mm	24 mm x 24 mm	61-9930.0
	Plastic	Silver		21 mm x 21 mm	24 mm x 24 mm	61-9930.4
	Plastic	Black		21 mm x 27 mm	24 mm x 30 mm	61-9931.0
	Plastic	Silver		21 mm x 27 mm	24 mm x 30 mm	61-9931.4
For indicator, illuminated pushbutton, mushroom-head pushbutton and keylock switch	Aluminium	Nature	anodised	Ø 22.3 mm	Ø 25 mm	61-9933.0
	Aluminium	Black	anodised	Ø 22.3 mm	Ø 25 mm	61-9933.1
	Aluminium	Red	anodised	Ø 22.3 mm	Ø 25 mm	61-9933.2
	Plastic	Black		Ø 22.3 mm	Ø 25 mm	61-9933.10
For selector switch	Aluminium	Nature	anodised	Ø 22.3 mm	Ø 25 mm	61-9932.0
	Aluminium	Black	anodised	Ø 22.3 mm	Ø 25 mm	61-9932.1
	Plastic	Black	anodised	Ø 22.3 mm	Ø 25 mm	61-9932.10
	Plastic	Black		21 mm x 21 mm	24 mm x 24 mm	61-9936.0

Additional information

- The colour of anodised aluminium parts can vary due to technical production reasons



Front bezel set mushroom head pushbutton

Front bezel material	Front bezel colour	Front bezel type	Dimensions	Part No.
Aluminium	Nature	flush	Ø 40 mm	61-9934.8

Additional information

- The colour of anodised aluminium parts can vary due to technical production reasons

71 Components



Single-LED, T1 3/4 MG

Illumination colour	Operating voltage	Operation current	Lumi. Intensity	Dom. Wavelength	Part No.	Wiring diagram
Red	6 V DC +10%	15 mA ±15 %	350 mcd	630 nm	10-2J06.3142	55
	12 V AC/DC +10%	7 - 14 mA ±15 %	330 mcd	630 nm	10-2J09.1062	55
	24 V AC/DC +10%	7 - 14 mA ±15 %	330 mcd	630 nm	10-2J12.1062	55
	28 V AC/DC +10%	7 - 14 mA ±15 %	330 mcd	630 nm	10-2J13.1062	55
	48 V AC/DC +10%	4 - 8 mA ±15 %	200 mcd	630 nm	10-2J19.1042	55
Yellow	6 V DC +10%	15 mA ±15 %	300 mcd	587 nm	10-2J06.3144	55
	12 V AC/DC +10%	7 - 14 mA ±15 %	280 mcd	587 nm	10-2J09.1064	55
	24 V AC/DC +10%	7 - 14 mA ±15 %	280 mcd	587 nm	10-2J12.1064	55
	28 V AC/DC +10%	7 - 14 mA ±15 %	280 mcd	587 nm	10-2J13.1064	55
	48 V AC/DC +10%	4 - 8 mA ±15 %	180 mcd	587 nm	10-2J19.1044	55
Green	6 V DC +10%	7 mA ±15 %	1050 mcd	525 nm	10-2J06.3145	55
	12 V AC/DC +10%	4 - 7 mA ±15 %	1050 mcd	525 nm	10-2J09.1065	55
	24 V AC/DC +10%	4 - 7 mA ±15 %	1050 mcd	525 nm	10-2J12.1065	55
	28 V AC/DC +10%	4 - 7 mA ±15 %	1050 mcd	525 nm	10-2J13.1065	55
	48 V AC/DC +10%	2 - 4 mA ±15 %	600 mcd	525 nm	10-2J19.1045	55
Blue	6 V DC +10%	15 mA ±15 %	680 mcd	470 nm	10-2J06.3146	55
	12 V AC/DC +10%	4 - 14 mA ±15 %	650 mcd	470 nm	10-2J09.1066	55
	24 V AC/DC +10%	7 - 14 mA ±15 %	650 mcd	470 nm	10-2J12.1066	55
	28 V AC/DC +10%	7 - 14 mA ±15 %	650 mcd	470 nm	10-2J13.1066	55
	48 V AC/DC +10%	4 - 8 mA ±15 %	400 mcd	470 nm	10-2J19.1046	55
White	6 V DC +10%	6 mA ±15 %	900 mcd	x: 0,31 / y: 0,32 nm	10-2J06.3149	55
	12 V AC/DC +10%	3 - 6 mA ±15 %	900 mcd	x: 0.31 / y: 0.32 nm	10-2J09.1069	55
	24 V AC/DC +10%	2,5 - 5 mA ±15 %	750 mcd	x: 0.31 / y: 0.32 nm	10-2J12.1069	55
	28 V AC/DC +10%	2,5 - 5 mA ±15 %	750 mcd	x: 0.31 / y: 0.32 nm	10-2J13.1069	55
	48 V AC/DC +10%	2 - 4 mA ±15 %	600 mcd	x: 0.31 / y: 0.32 nm	10-2J19.1049	55

Additional information

- Due to high surface temperatures, the series resistor must not be soldered directly to the terminals of the equipment (use a terminal plate)
- When using AC/DC types with AC operation, slight flickering can occur
- The luminous intensity stated is for when used with DC
- Electrical and optical data are measured at 25 °C
- The specified versions are built with a protection diode (halve wave rectifier) in series and the LED
- Luminosity and wave length variations caused by LED manufacturing processes may cause slight differences regarding the illumination. The customer has to decide what resistor shall be used to the LED
- Where supply voltages are over 48 V, a voltage-reduction element (external protective series resistor) must be used.
- Keep to the country specific safety instructions

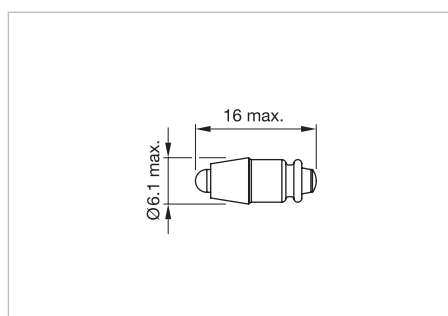

Dimensions [mm]

Wiring diagrams

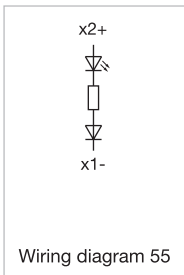

Bi-colour LED, BA9s

Illumination colour	Operating voltage	Operation current	Lumi. Intensity	Dom. Wavelength	Part No.	Wiring diagram
Red / Green	24 V DC +10%	15/14 mA ±15 %	600/630 mcd	625 / 525 nm	10-A312.314A	171

Additional information

- Due to high surface temperatures, the series resistor must not be soldered directly to the terminals of the equipment (use a terminal plate)
- When using AC/DC types with AC operation, slight flickering can occur
- The luminous intensity stated is for when used with DC
- Electrical and optical data are measured at 25 °C
- The specified versions are built with a protection diode (half wave rectifier) in series and the LED
- Luminosity and wave length variations caused by LED manufacturing processes may cause slight differences regarding the illumination. The customer has to decide what resistor shall be used to the LED
- Where supply voltages are over 48 V, a voltage-reduction element (external protective series resistor) must be used.

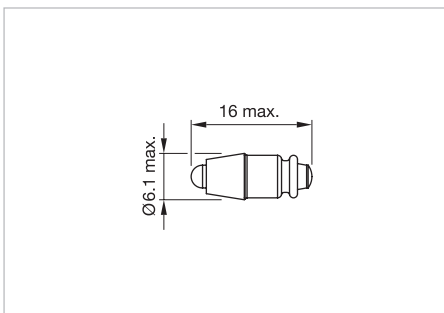

Dimensions [mm]

Wiring diagrams

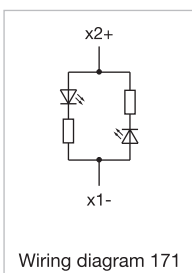

71 Components



Switching element

Switching system	Contacts	Contact material	Terminal	Part No.	Wiring diagram	Component Layout
Snap-action switching element	1 NC / 1 NO	Gold	PCB terminal	71-671.026	336	83
	2 NC / 2 NO	Gold	PCB terminal	71-672.026	335	83

Wiring diagrams

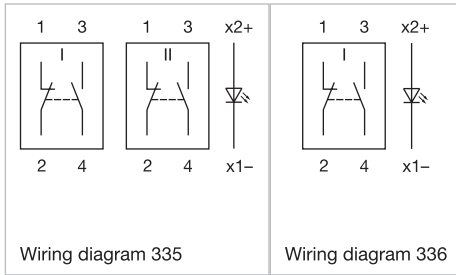

Component layouts

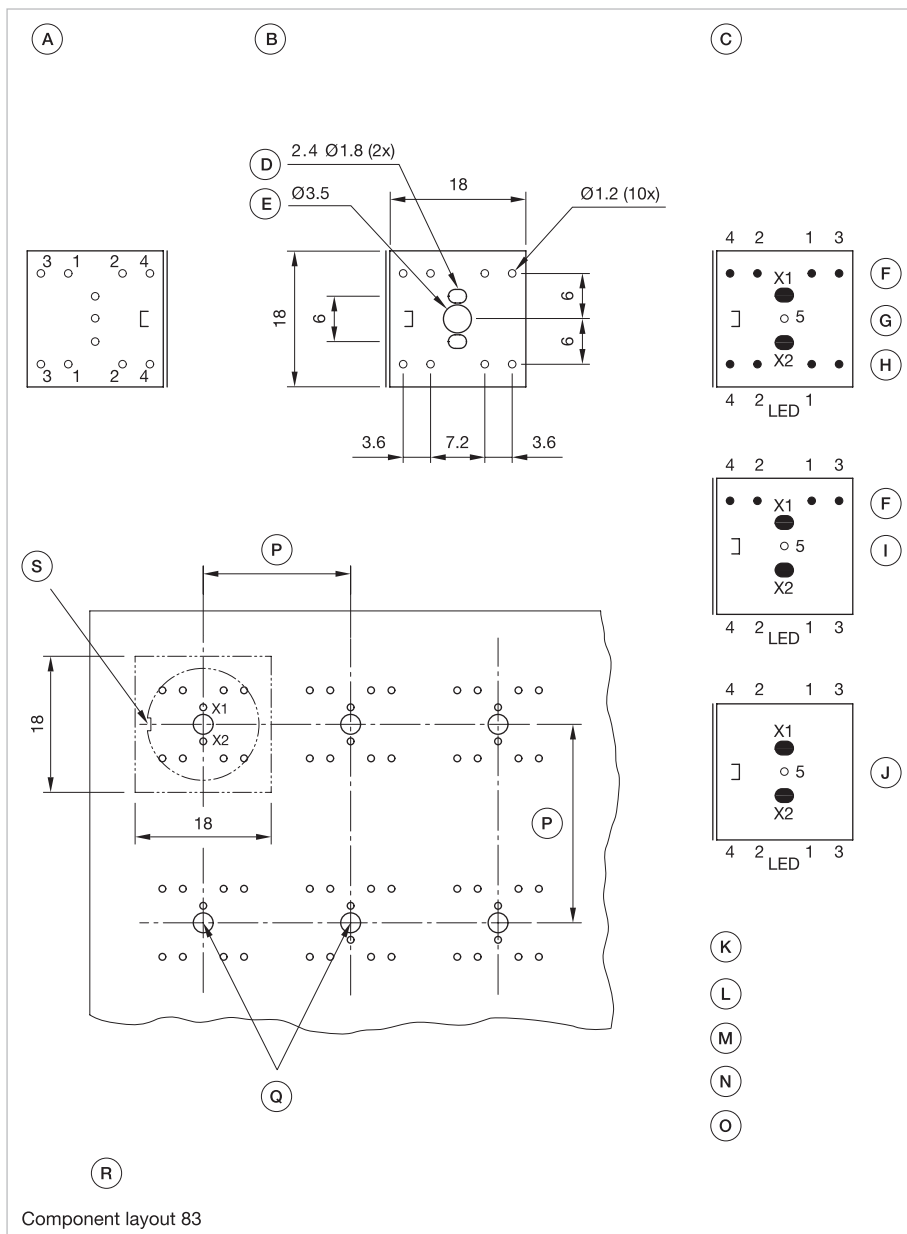

Component layout 83

Dimensions [mm]

- A = Terminals (rear side)
- B = Drilling plan (component side)
- C = non-metallic
- D = Cu-Pad
- E = Occupancy plan (component side)
- F = 1. Switch
- G = Switching element 2 Normally close + 2 Normally open, Part No. 71-672.026
- H = 2. Switches
- I = Switching element 1 Normally close + 1 Normally open, Part No. 71-671.026
- J = Illumination element, Part No. 71-670.026
- K = X1 Lamp cathode (-)
- L = X2 Lamp anode (+)
- M = 1-2 Contact normally closed
- N = 3-4 Contact normally open
- O = 5 Hole for interlocking pin
- P = Front dimension min.
- Q = Position interlocking pin
- R = Note:
Pitch of the print circuit board hole Ø3.5 must agree with the mounting holes on the front plate
- S = Slot in actuator

01
02
03
04
09
14
17
18
19
22
31
41
45
51
56
57
61
70
71
82
84
92
96

71 Components



Switching element

Terminal	Material	Part No.	Wiring diagram	Component Layout
PCB terminal	plastic	71-670.006	68	83

Additional information

- Including locking pin

Wiring diagrams

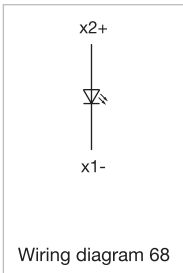

Follow us.
We are on LinkedIn!
EAO creates possibilities. Since 1947.



 [Come take a look at our LinkedIn profile today!](https://www.linkedin.com/company/eao/) Be sure to give us a follow so that you can fully interact with us.

<https://www.linkedin.com/company/eao/>

www.eao.com

eao ■
Your Expert Partner for Human Machine Interfaces

Component layouts

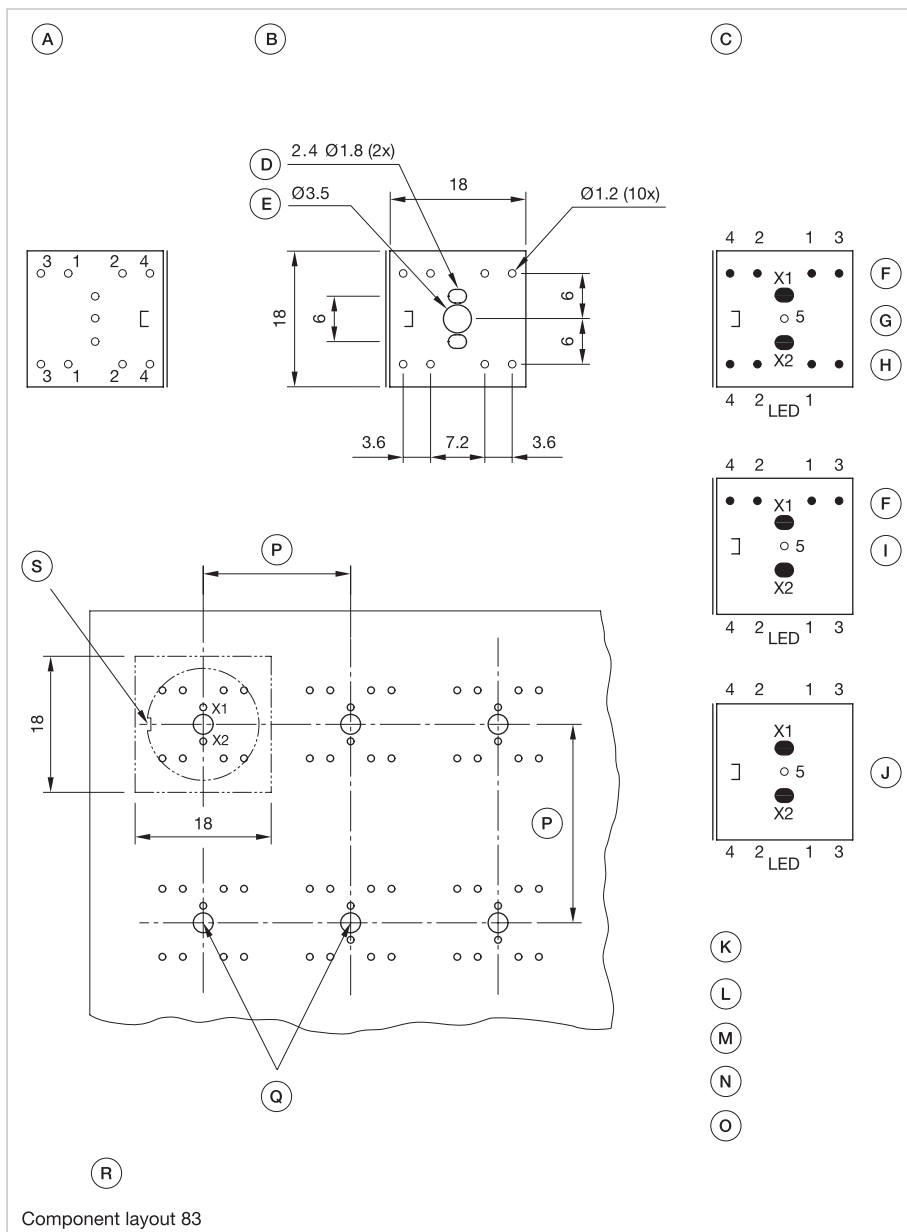

Component layout 83

Dimensions [mm]

- A = Terminals (rear side)
- B = Drilling plan (component side)
- C = non-metallic
- D = Cu-Pad
- E = Occupancy plan (component side)
- F = 1. Switch
- G = Switching element 2 Normally close + 2 Normally open, Part No. 71-672.026
- H = 2. Switches
- I = Switching element 1 Normally close + 1 Normally open, Part No. 71-671.026
- J = Illumination element, Part No. 71-670.026
- K = X1 Lamp cathode (-)
- L = X2 Lamp anode (+)
- M = 1-2 Contact normally closed
- N = 3-4 Contact normally open
- O = 5 Hole for interlocking pin
- P = Front dimension min.
- Q = Position interlocking pin
- R = Note:
Pitch of the print circuit board hole Ø3.5 must agree with the mounting holes on the front plate
- S = Slot in actuator

71 Components



Anti-twist ring

Material	Mounting cut-out	Part No.
metal	Ø 22.3 mm	61-9912.0

- 01
- 02
- 03
- 04
- 09
- 14
- 17
- 18
- 19
- 22
- 31
- 41
- 45
- 51
- 56
- 57
- 61
- 70
- 71**
- 82
- 84
- 92
- 96

Front side



Blind plug

Dimensions	Material	Colour	Mounting cut-out	Part No.
24 mm x 24 mm	plastic	Black	21 mm x 21 mm	61-9451.0
24 mm x 30 mm	plastic	Black	21 mm x 27 mm	61-9452.0
Ø 25 mm	plastic	Black	Ø 25 mm	61-9453.0

Additional information

- Please note that bigger minimum distances are necessary

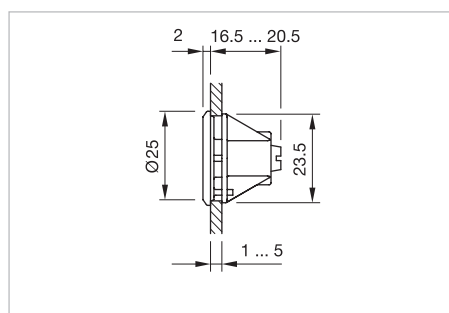

Dimensions [mm]
for Part No. 61-9453.0



Key protection cap

Product attributes	Material	Colour	Part No.
For standard lock: DOM	plastic	Black	31-985.0



Spare key

Product attributes	Material	Part No.
Standard lock: DOM 311	metal	31-989.311

Additional information

- Optional lock numbers on request



Protective cap

Product attributes	Material	Colour	Optics	Part No.
For front bezel set 24 mm x 30 mm, flush design	silicone	Colourless	transparent	61-9927.2
For front bezel Ø 25 mm	silicone	Colourless	transparent	84-9103.7

Additional information

- For flat lens profil only
- When using the front protection cover the external sealing in the actuator has to be removed

01
02
03
04
09
14
17
18
19
22
31
41
45
51
56
57
61
70
71
82
84
92
96

71 Accessories



Master key

Product attributes	Material	Part No.
For standard lock: DOM 311 ... 445	metal	31-989.300



Protective cover flush design

Product attributes	Dimensions	Material	Colour	Optics	Mounting cut-out	Part No.
Hinged, with means for sealing, for device with front dimension 24 mm x 24 mm	24 mm x 24 mm	plastic	Colourless	transparent	21 mm x 21 mm	61-9921.0
Hinged, with means for sealing, for device with front dimension 24 mm x 30 mm	30 mm x 24 mm	plastic	Colourless	transparent	27 mm x 21 mm	61-9922.0
Slide by side, without cover locking hole, for device with front dimension Ø 25 mm	Ø 25 mm	plastic	Colourless	transparent	Ø 22.3 mm	61-9924.0

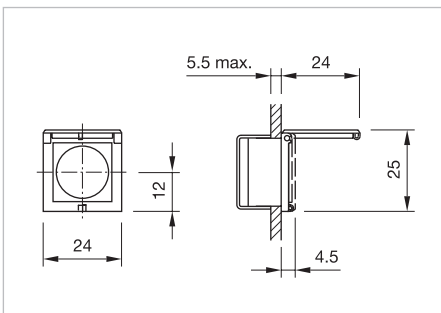

Dimensions [mm]
for Part No. 61-9921.0

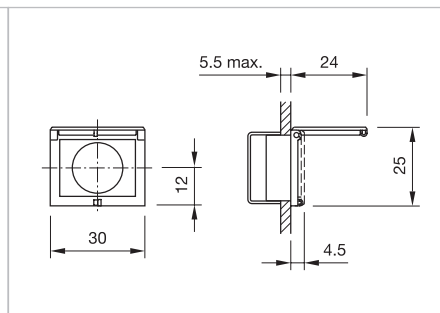

Dimensions [mm]
for Part No. 61-9922.0

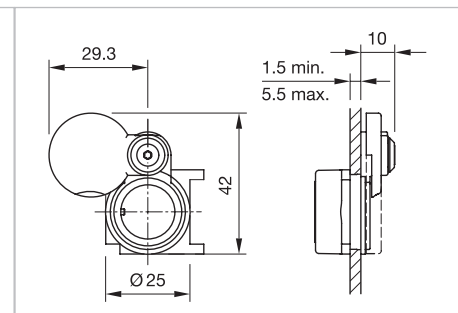

Dimensions [mm]
for Part No. 61-9924.0

Rear side



Interlocking pin

Material	Part No.
plastic	71-679.0



Series resistor

Operating voltage	Resistance	Part No.
110 V AC	2.7 kOhm	02-904.0
125 V AC	3.3 kOhm	02-904.1
145 V AC	4.7 kOhm	02-904.3
240 V AC	10 kOhm	02-904.7

Additional information

- Only for filament lamp 48 VAC, 25 mA
- Due to high surface temperatures, the series resistor must not be soldered directly to the terminals of the equipment (use a terminal plate)
- Keep to the country specific safety instructions



Follow us.
We are on YouTube!
EAO ermöglicht. Seit 1947.



[Come take a look at our YouTube profile today!](https://www.youtube.com/user/eaoswitches) Be sure to give us a follow so that you can fully interact with us.

<https://www.youtube.com/user/eaoswitches>

71 Accessories

Mounting



Lens remover

Product attributes	Material	Part No.
For flush design	metal / plastic	61-9730.0



Lamp remover

Product attributes	Material	Part No.
A switching action may occur when replacing the lamp	plastic	61-9740.0



Mounting tool

Product attributes	Dimensions	Material	Part No.
For tightening or loosening of the fixing nut Ø 16 mm	Ø 16 mm	metal	01-907

System switch 71

Switching system

Self-cleaning, double-break snap-action switching system with one NC- (Normally closed) and one NO-contact (Normally open) (Make before brake).

Material

Lens

Plastic or Aluminium anodized

Front bezel

Plastic, as per UL 94 V0 or Aluminium anodized

Material of contact

AgNi, 2 µm gold plated

Switching element

Plastic, as per UL 94 V0

Actuator housing

Plastic, as per UL 94 V0

Mechanical characteristics

Terminals

PCB terminal, Brass gold plated

Tightening torque

For fixing nut max. 0.5 Nm

Actuating torque

Selector-/Keylock switch 0.04 Nm ... 0.08 Nm

Actuating force

Pushbutton 2 N ... 3 N

Actuating travel

Pushbutton approx. 3 mm

Selector-/keylock switch	2 positions	3 positions
Momentary action	approx. 42°	approx. 2 x 42°
Maintained action	approx. 90°	approx. 2 x 90°

Mechanical lifetime

Pushbutton maintained action	1 million cycles of operation
Pushbutton momentary action	2 million cycles of operation
Keylock switch	50 000 cycles of operation
Selector switch	100 000 cycles of operation

Resistance to heat of soldering

Manual soldering 350 °C, 3 sec.
Flow soldering 260 °C, 5 sec.

Electrical characteristics

Switching voltage and switching current

Switch rating AC cosφ 0.7 ... 0.8
Voltage 250 VAC
Current 3 A

Switch rating DC

Voltage 24 VDC 250 VDC
Current 3 A 0.5 A

Recommended minimum operational data

Voltage 5 VAC
Current 10 mA

Electric strength

2000 VAC, 50 Hz, 1 minute between all terminals and earth

Ambient conditions

Storage temperature

-40 °C ... +85 °C

Operating temperature

-25 °C ... +55 °C

Protection degree

IP65 front side

Shock resistance

(semi-sinusoidal)
Max. 500 m/s², pulse width 11 ms, 3-axis,
as per EN IEC 60068-2-27

Vibration resistance

(sinusoidal)
Max. 100 m/s² at 10 Hz ... 500 Hz, as per EN IEC 60068-2-6

Climate resistance

Damp heat, state
56 days, +40 °C/93 % relative humidity, as per EN IEC 60068-2-78

Approvals

Approbations

CQC

Conformities

CE
UKCA
2014/35/EU (LVD)
2011/65/EG (RoHS)

71 Technical data

Lens plastic with symbols

Chemical and mechanical tests

1. Wipe resistance according to EN 61058-1 section 8.9
(Petrol/gasoline, distilled water, diluted alcohol)
2. Graffiti-Killer Test
3. Railway cleaning agents (Walo)
4. Damp/dry heat durability
5. UV test according to EN 60068-2-5/56 days
6. Mechanical life time 2 Mio. Operations (abrasive test)

EAO reserves the right to alter specifications without further notice.

General notes

1. Engraving

In addition to the most commonly used world languages, in DIN1451-3 close spacing, other typefaces are available as Scandinavian, Slavic, Greek, Russian and Polish. Red, blue and black lenses are filled with white colour. Other colour lenses are filled in black. Standard height of letters is 2 mm. If the height is not specified, we will supply 2 mm engraved letters.

2. Hot stamping

For larger series it is worth considering markings by means of hot stamping. We will be pleased to advise you.

3. Film inserts

Instead of using engraving the lenses can be fitted with transparent film inserts, as an alternative. In the case of use of a smoke-black lens the fitted film becomes readable only if the lamp is on. The film thickness is 0.2 mm. For lenses Ø 24 mm and Ø 25 mm with Part No. 619642.x the marking takes place directly on the text plate Part No. 61-9707.7, instead of a film insert.

Important: Consider pushbutton mounting orientation before specifying engraving characters!

Lenses for indicators and illuminated pushbuttons, raised mounting

All dimensions in mm

Front size (Lens)	Film insert max. size	Height of letters h	Number of lines	Number of capital letters per line (target value)	Number of small letters per line (target value)	Image
24 x 30 (18 x 24)	15.1 x 21	2.5	4	10	11	B1
		3	3	8	9	B1
		4	2	6	7	B1
		5	2	5	6	B1
		6	1	4	5	B1
		8	1	3	3	B1
		2.5	5	7	8	B2
		3	4	6	7	B2
		4	3	5	5	B2
		5	3	4	4	B2
		6	2	3	3	B2
		8	2	2	2	B2
15.1 x 15.1	15.1 x 15.1	2.5	4	7	8	B3
		3	3	6	7	B3
		4	2	5	5	B3
		5	2	4	4	B3
		6	1	3	3	B3
Ø 24 (Ø 18)	Textplatte (Ø 15.6)	2.5	3	6-7	6-8	B4
		3	3	4-6	5-7	B4
		4	2	4	4-5	B4
		5	2	2-3	3	B4
		6	2	2	2-3	B4
8	1	2	2	B4		

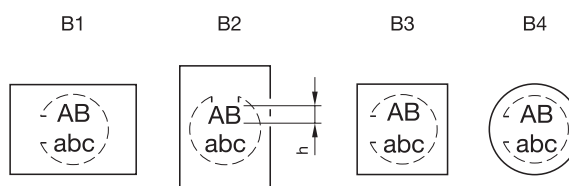
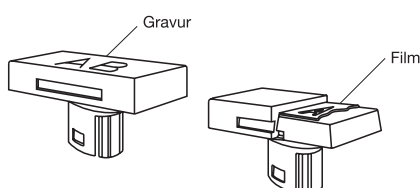

71 Application guidelines

Suppressor circuits

When switching inductive loads such as relays, DC motors, and DC solenoids, it is always important to absorb surges (e.g. with a diode) to protect the contacts. When these inductive loads are switched off, a counter emf can severely damage switch contacts and greatly shorten lifetime.

Fig. 1 shows an inductive load with a free-wheeling diode connected in parallel. This free-wheeling diode provides a path for the inductor current to flow when the current is interrupted by the switch. Without this free-wheeling diode, the voltage across the coil will be limited only by dielectric breakdown voltages of the circuit or parasitic elements of the coil. This voltage can be kilo-

volts in amplitude even when nominal circuit voltages are low (e.g. 12VDC) see Fig. 2.

The free-wheeling diode should be chosen so that the reverse breakdown voltage is greater than the voltage driving the inductive load. The DC blocking voltage (V_R) of the free-wheeling diode can be found in the datasheet of a diode. The forward current should be equal or greater than the maximum current flowing through the load.

To get an efficient protection, the free-wheeling diode must be connected as close as possible to the inductive load!

Switching with inductive load
Fig. 1

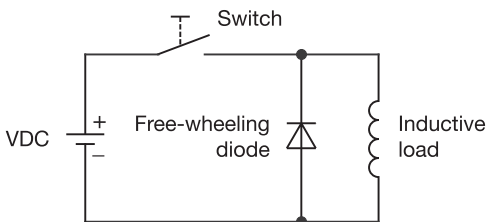

Counter EMF
over load without free-wheeling diode
Fig. 2

