

Series 09

In-Cabin Keypads

Modular and reliable, for vehicle interiors.

www.eao.com/09



Company IATF 16949 certified



Series 09 In-Cabin Keypads

Modular and reliable, for vehicle interiors.

These configurable HMIs are developed in accordance with IATF 16949 and can be combined within a modular design – for reliable and safe E1 applications in the interiors of heavy-duty and special vehicles.

Technological advances and high-tech vehicle design are of growing importance for both heavy-duty and special vehicles. This trend is reflected by the Series 09 In-Cabin Keypads with their high-quality modular automotive design, which provides up to IP5K4 front protection. These durable HMIs are developed in accordance with the internationally recognised automotive standard IATF 16949 and feature impressive application-specific configuration options for the illumination and the communication interfaces as well as the possibility to make a customised selection and arrangement of the symbols.

Modern drivers' workstations in heavy-duty and special vehicles, as well as the applications in their interior areas, pose increasingly demanding requirements in terms of the safety, functionality, reliability and the design of their operating systems. This is as true for vehicles and machines used for construction and agriculture as it is for fire engines, refuse collection and cleaning vehicles, and trucks or buses. As a leading manufacturer and developer of application-specific and ergonomic HMI components and systems in the automotive industry we have a deep understanding of design considerations in respect of ergonomic and application-specific HMI control units.

This is hugely beneficial for our customers, enabling them to access individual solutions for applications in the field of heavy-duty and special vehicles.

Classic applications within a vehicle such as switching headlights on or off, or operating the windscreen wiper, are included here as much as specific applications for the relevant vehicle type.

Typical applications

- Vehicle headlights, position lights and sidelights
- Windscreen washing system and air conditioning system
- Hazard warning lights
- Navigation in display menus or user interfaces
- All-round lighting and warning signals
- Controlling side supports, cleaning brushes or a mower
- Controlling pumps or hydraulics
- And many more

Modular design and easy installation

The low installation depth and quick snap-in or screw mounting enable flexible and straightforward installation with either vertical or horizontal alignment. At the same time, the In-Cabin Keypads can be combined with one another on a modular basis. The versions with six pushbuttons and two pushbuttons can be installed as an additional mounting option.

Individual halo-ring and symbol illumination

The HMIs offer freely configurable RGB or single LED halo-ring illumination. The white LED symbol illumination can also be controlled separately. Constant illumination, slow or fast flashing, or pulsing illumination can be programmed as illumination functions. This creates an almost-limitless variety of illumination options, and therefore a huge range of potential applications – for rapid identification of the HMI, functional illumination, and intuitive, visual HMI feedback.

Interchangeable ISO 7000 or customer-specific symbols

The symbol inserts for the pushbuttons can be selected precisely in accordance with customer requirements, and specific to the relevant application. They can be inserted at 90-degree increments and feature innovative illumination – whether for ISO 7000 or customer-specific symbols. Thanks to the LED background illumination, the correct application can always be found quickly, even in difficult light conditions.

Advantages.

- Programmable RGB halo ring and symbol illumination (can be controlled separately)
- High-quality modular automotive design with IP5K4 front protection
- Reliable HMI developed according to recognised automotive standard IATF 16949
- Available with CAN bus connection or as hard-wired variants
- Interchangeable ISO 7000 or customer-specific symbols

Manufacturing competence and IATF 16949

The Series 09 modules are produced in our automotive competence centre located in Germany. This allows us to apply years of comprehensive experience as an original equipment manufacturer (OEM) in the automotive industry to the heavy-duty and special vehicle markets. At the same time, this offers EAO customers high-quality, durable, and intuitive products and services. The development and production process is aligned and executed according to automotive standards (IATF 16949, 100 % product traceability, 100 % EOL testing, etc.).

More than an expert – A partner of the automotive industry

As a global partner to major automotive manufacturers and suppliers, we provide our customers with high-quality products and services. Through many decades of commitment and consultation with the automotive industry, EAO is an established global supplier of operator control panels, sub-assemblies, switches, buttons and indicators.

Mechanical characteristics

- Actuating force: approx. 6 N
- Overload force: 250 N
- Mechanical lifetime: up to 1 million cycles of operation
- Impact resistance: IEC 62262 IK07

Electrical characteristics

- Operating voltage range: 8–32 VDC

Illumination

- The halo-ring and symbol illumination can be configured independently of one another
- Halo-ring effects: flashing, pulsing, colour change (depending on product version)
- LED symbol illumination
 - Colour: white LED
 - Luminance: approx. 20 cd/m² (dimnable)

- LED halo-ring illumination
 - RGB or single-colour LED (depending on product version)
 - Luminance: approx. 500 cd/m² (dimnable)

Symbols

- Symbols in accordance with ISO 7000
- Customer-specific symbols on request

Ambient conditions

- Operating temperature: –40 °C ... +85 °C
- Storage temperature: –40 °C ... +85 °C

Protection degree

- IP5K4 in accordance with ISO 20653 (front side in installed state)
- IP20 in accordance with ISO 20653 (rear side)

Approvals and conformities

- Developed and produced according to IATF 16949
- E1 ECE R10/ECE R118 (in implementation)
- CE

Examples of unit combinations

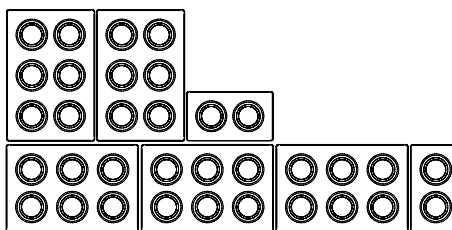

Further information is available under
www.eao.com/09









Customer-specific product diversity.

Series 09 In-Cabin Keypads with 6 pushbuttons are available in SUPER, PLUS and BASIC variants. These differ in terms of illumination options and the communication interface. The hard-wired BASIC product variant is available, as an additional option, in a 2-pushbutton version.

With this wide range of variants, customers can choose between a CAN bus connection or hard-wired version depending on their application, and they can further customise their keypad thanks to a variety of illumination options and interchangeable custom or ISO 7000 symbols – for optimal integration of the HMI in the vehicle interior.

Product	Variant	Symbol illumination	Halo-ring illumination	Communication protocol	IP protection class	Plug	Switching action	Safety
Keypad 6PB 	SUPER	White LED	RGB, freely configurable	CANopen, J1939	IP5K4	TYCO 1745000-3	Pushbutton	Diagnostic switching action for ASIL QM (B) in accordance with ISO 26262
Keypad 6PB 	PLUS	White LED	Red LED (other colours on request)	CANopen, J1939	IP5K4	TYCO 1745000-3	Pushbutton	Diagnostic switching action for ASIL QM (B) in accordance with ISO 26262
Keypad 6PB 	BASIC	White LED	Red LED	n/a (hard-wired)	IP5K4	TYCO 1745000-3/ 1745000-4	Pushbutton	Diagnostic switching action for ASIL QM (B) in accordance with ISO 26262 (with NAMUR)
Keypad 2PB 	BASIC	White LED	Red LED	n/a (hard-wired)	IP5K4	TYCO 1745000-3	Pushbutton	Diagnostic switching action for ASIL QM (B) in accordance with ISO 26262 (with NAMUR)

6-pushbutton Keypad SUPER.



Mechanical characteristics

- Actuating force: approx. 6 N
- Overload force: 250 N
- Lifecycle: up to 1 million cycles of operation
- Impact resistance: IEC 62262 IK07

Electrical characteristics

- Operating voltage range 8-32 VDC LoadDump A or B

Illumination

- Halo-ring and symbol illumination can be configured independently of one another
Halo-ring effects: flashing, pulsing, colour change
- LED symbol illumination
 - Colour: white
 - Luminance: approx. 20 cd/m² (dimnable)
- LED halo-ring illumination
 - Colour: multi-colour RGB
 - Luminance: approx. 500 cd/m² (dimnable*)

*depending on the respective colour

Symbols

- Symbols in accordance with ISO 7000
- Customer-specific symbols on request

Connections/interfaces

- CAN interface (ISO 11898)
- CAN protocols: CANOpen (CiA 401), CAN J1939
- Baud rate 125, 250, 500, 1000 kBit/s (configurable through software)
- Integrated plug recess, compatible with TE 8P-1745000-3

Protection degree

- IP5K4 in accordance with ISO 20653 (front side in installed state)
- IP20 in accordance with ISO 20653 (rear side)

Ambient conditions

- Operating temperature -40°C ... +85°C
- Storage temperature -40°C ... +85°C

Dimensions

(All dimensions in mm)

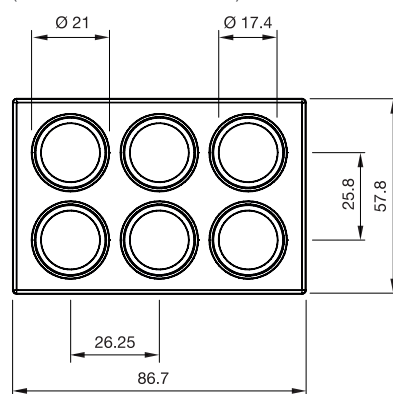

Mounting cut-out

(Panel thickness 1.0 mm ... 4.0 mm)

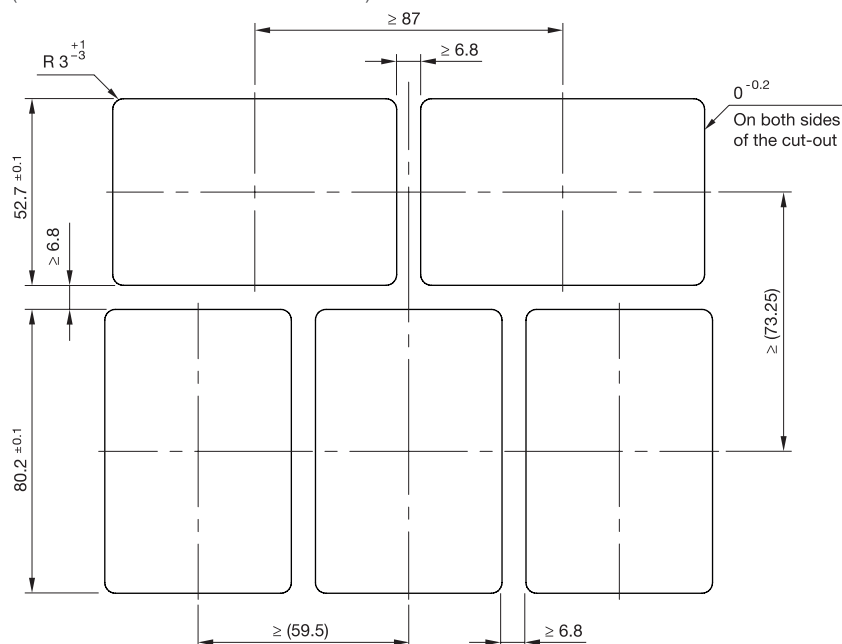

Mounting

Clip-in mounting

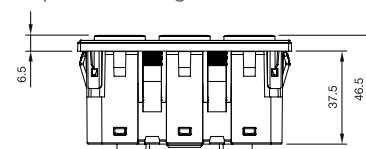

Screw-in mounting

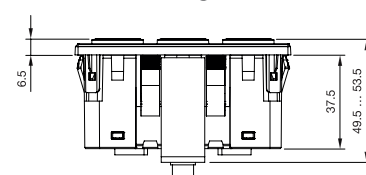

The keypad can be mounted into front plate thicknesses between 1 and 4 mm. A front plate of at least 2 mm thickness is recommended. Non-compliance with these specifications may lead to damage to the locking tongue.

6-pushbutton Keypad PLUS.



Mechanical characteristics

- Actuating force: approx. 6 N
- Overload force: 250 N
- Lifecycle: up to 1 million cycles of operation
- Impact resistance: IEC 62262 IK07

Electrical characteristics

- Operating voltage range 8-32 VDC LoadDump A or B

Illumination

- Halo-ring and symbol illumination can be configured independently of one another
Halo-ring effects: flashing, pulsing, colour change
- LED symbol illumination
 - Colour: white
 - Luminance: approx. 20 cd/m² (dimnable)
- LED halo-ring illumination
 - Colour: red (other colours on request)
 - Luminance: approx. 500 cd/m² (dimnable)

Symbols

- Symbols in accordance with ISO 7000
- Customer-specific symbols on request

Connections/interfaces

- CAN interface (ISO 11898)
- CAN protocols: CANOpen (CiA 401), CAN J1939
- Baud rate 125, 250, 500, 1000 kBit/s (configurable through software)
- Integrated plug recess, compatible with TE 8P-1745000-3

Protection degree

- IP5K4 in accordance with ISO 20653 (front side in installed state)
- IP20 in accordance with ISO 20653 (rear side)

Ambient conditions

- Operating temperature -40°C ... +85°C
- Storage temperature -40°C ... +85°C

Dimensions

(All dimensions in mm)

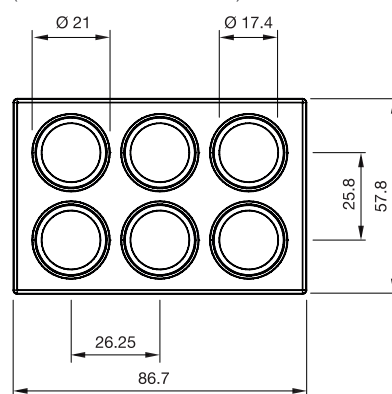

Mounting cut-out

(Panel thickness 1.0 mm ... 4.0 mm)

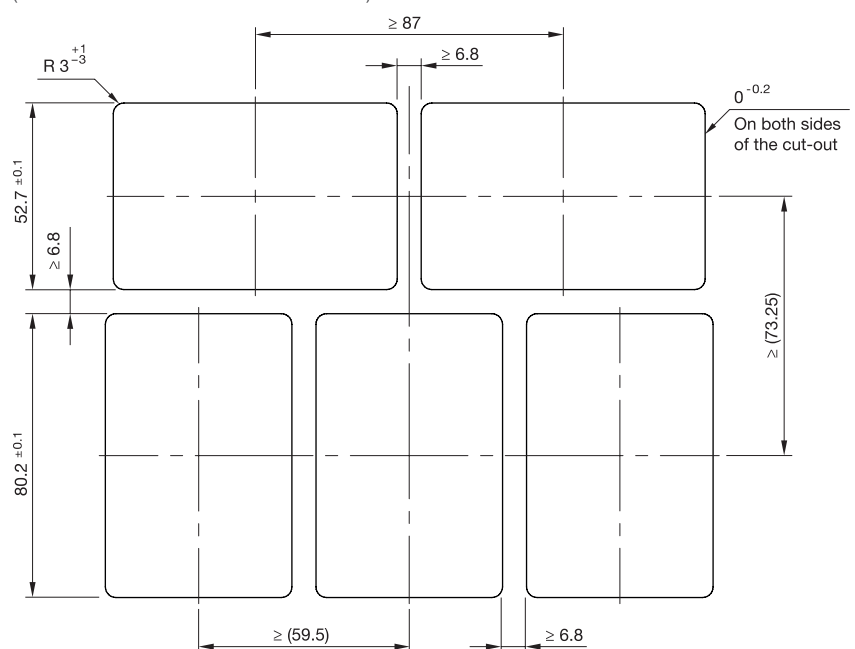

Mounting

Clip-in mounting

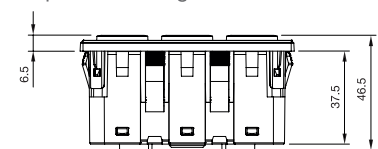

Screw-in mounting

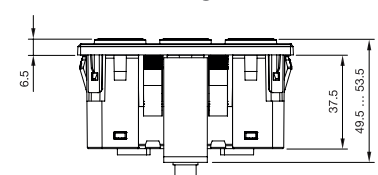

The keypad can be mounted into front plate thicknesses between 1 and 4 mm. A front plate of at least 2 mm thickness is recommended. Non-compliance with these specifications may lead to damage to the locking tongue.

Dimensions
(All dimensions in mm)

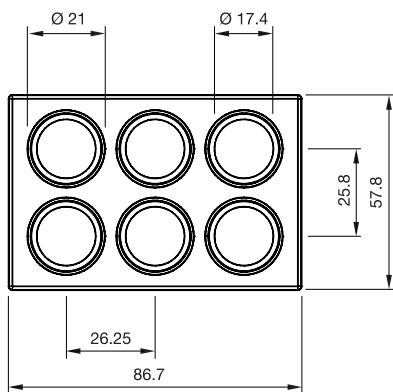

Mounting
Clip-in mounting

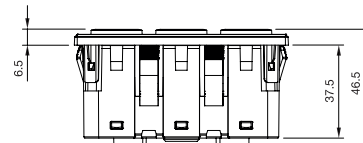

Screw-in mounting

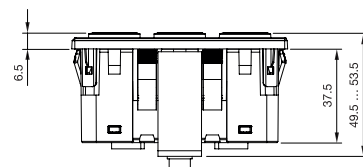

The keypad can be mounted into front plate thicknesses between 1 and 4 mm. A front plate of at least 2 mm thickness is recommended. Non-compliance with these specifications may lead to damage to the locking tongue.

Mounting cut-out
(Panel thickness 1.0 mm ... 4.0 mm)

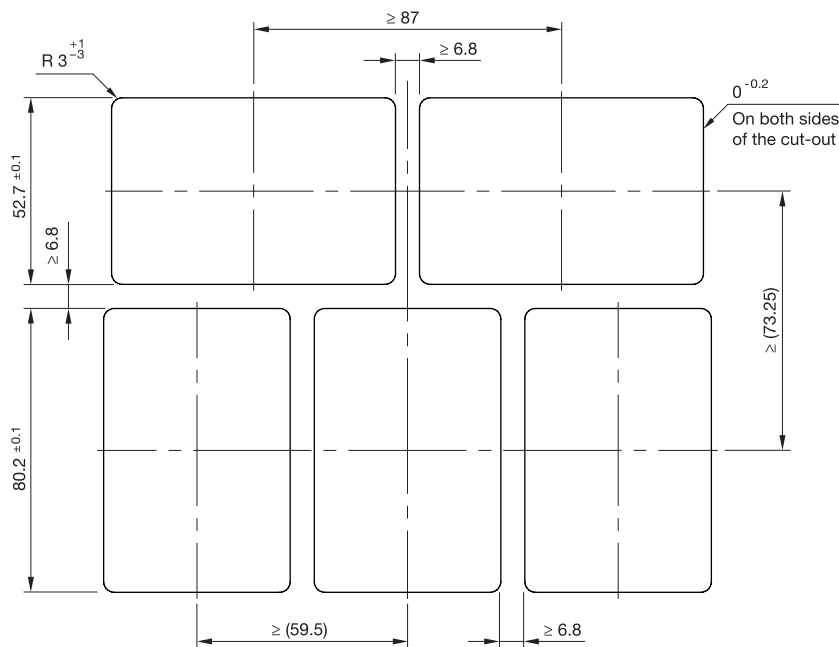

2-pushbutton Keypad BASIC.



Mechanical characteristics

- Actuating force: approx. 6 N
- Overload force: 250 N
- Lifecycle: up to 1 million cycles of operation
- Impact resistance: IEC 62262 IK07

Electrical characteristics

- Operating voltage range 8 – 32 VDC
Available with the option of diagnostic switching contacts (NAMUR)
- Max. power:
1 W (without NAMUR)
0.25 W (with NAMUR)
- Max. current:
30 mA
- Min. current:
2 mA
- Max. voltage:
32 V
- Contact resistance (unactuated):
> 2 MΩ (without NAMUR)
1 kΩ ± 4 % (with NAMUR)
- Contact resistance (actuated):
< 10 Ω (without NAMUR)
110 Ω ± 10 Ω (with NAMUR)

Illumination

- Halo-ring and symbol illumination can be configured independently of one another
- LED symbol illumination
 - Colour: white
 - Luminance: approx. 20 cd/m² (dimnable)
- LED halo-ring illumination
 - Colour: red (other colours on request)
 - Luminance: approx. 500 cd/m² (dimnable)

Symbols

- Symbols in accordance with ISO 7000
- Customer-specific symbols on request

Connections/interfaces

- Integrated plug recess, compatible with TE 8P-1745000-3/8P-1745000-4, 8-pin

Protection degree

- IP5K4 in accordance with ISO 20653 (front side in installed state)
- IP20 in accordance with ISO 20653 (rear side)

Ambient conditions

- Operating temperature
–40 °C ... +85 °C
- Storage temperature
–40 °C ... +85 °C

Dimensions

(All dimensions in mm)

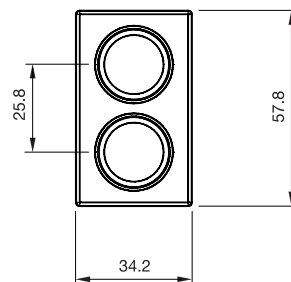

Mounting cut-out

(Panel thickness 1.0 mm ... 4.0 mm)

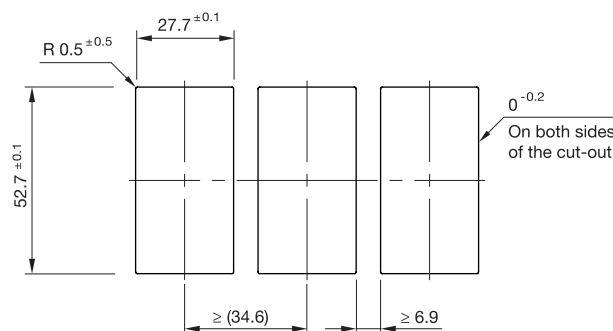

Mounting

Clip-in mounting

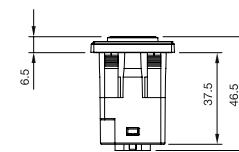

Screw-in mounting

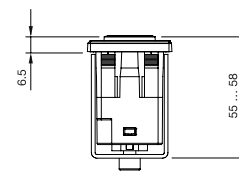

The keypad can be mounted into front plate thicknesses between 1 and 4 mm. A front plate of at least 2 mm thickness is recommended. Non-compliance with these specifications may lead to damage to the locking tongue.

Expert manufacturers. EAO creates possibilities since 1947.



Founding year: 1947

Number of employees: 600

Headquarters: Olten, Switzerland

Manufacturing Companies: Switzerland,
Germany, North America, China

Sales Companies: 10

Distribution countries: 50

Core markets: Heavy Duty & Special Vehicles,
Machinery, Transportation, Automotive

EAO AG, a Swiss, family-owned company founded in 1947, has developed into one of the world's leading manufacturers of high-quality switches, keyboards, sophisticated control elements, and complete HMI control units and HMI Systems.

Efficient and modern development processes, effective global supply chains, and skilled project and consultation management represent additional services that we offer our customers and business partners around the world.

Your solution-focused expert and partner

We do much more than just manufacture individual control elements. As a solution-focused partner, we provide the option of technically and mechanically customising existing HMI Components in line with our customers' individual requirements. From simple control elements through to sophisticated HMI Systems, from serial production through to installation – we offer the entire range of HMI services and inspire the confidence of our customers.

EAO Contact.

Your centre of excellence.

Headquarters

EAO Holding AG
Tannwaldstrasse 88
CH-4600 Olten
Telephone +41 62 286 92 00
info@eao.com

Manufacturing Companies

Switzerland
EAO AG
Tannwaldstrasse 88
CH-4600 Olten
Telephone +41 62 286 91 11
info@eao.com

EAO Systems AG
Tannwaldstrasse 88
CH-4600 Olten
Telephone +41 62 286 91 11
sales.esy@eao.com

China
EAO (Guangzhou) Ltd.
3/F, Block G4, South China
New Materials Innovation Park
31 Kefeng Road
Guangzhou Science City
CN-Guangzhou, PRC
Telephone +86 20 3229 0390
sales.ecn@eao.com

Germany
EAO Automotive GmbH & Co. KG
Richard-Wagner-Straße 3
DE-08209 Auerbach/Vogtland
Telephone +49 3744 8264 0
sales.esa@eao.com

North America
EAO Corporation
One Parrott Drive
Shelton
US-CT 06484
Telephone +1 203 951 4600
sales.eus@eao.com

Sales Companies

China
EAO (Guangzhou) Ltd.
3/F, Block G4, South China
New Materials Innovation Park
31 Kefeng Road
Guangzhou Science City
CN-Guangzhou, PRC
Telephone +86 20 3229 0390
sales.ecn@eao.com

EAO (Shanghai) Office
Rm.401, Lihpao Plaze,
NO.159 Shenwu Road,
Minhang District,
CN-Shanghai, 201106.
PRC
Telephone +86 21 6095 0717
sales.ecn@eao.com

France
EAO France SAS
27 rue Maurice Flandin
FR-69003 Lyon
Telephone +33 426 298 588
sales.efr@eao.com

**Germany, Austria, Czech Republic,
Poland, Slovakia**
EAO GmbH
Langenberger Straße 570
DE-45277 Essen
Telephone +49 201 8587 0
sales.ede@eao.com

Hong Kong (Asia Pacific)
EAO (Far East) Ltd.
Unit A1, 1/F, Block A
Tin On Industrial Building
777 Cheung Sha Wan Road
Lai Chi Kok, Kln
HK-Hong Kong
Telephone +852 27 86 91 41
sales.ehk@eao.com

Italy
EAO Italia S.r.l.
Centro Direzionale Summit –
Palazzo C1
Via Brescia 26
IT-20063 Cernusco sul Naviglio (MI)
Telephone +39 029 247 0722
sales.eit@eao.com

Japan
EAO Japan Co. Ltd.
Net 1 Mita Bldg. 3F
3-1-4 Mita Minato-ku
JP-Tokyo 108-0073
Telephone +81 3 5444 5411
sales.ejp@eao.com

Netherlands, Belgium
EAO Benelux B.V.
Kamerlingh Onnesweg 46
NL-3316 GL Dordrecht
Telephone +31 78 653 17 00
sales.enl@eao.com

North America
EAO Corporation
One Parrott Drive
Shelton
US-CT 06484
Telephone +1 203 951 4600
sales.eus@eao.com

Switzerland
EAO Schweiz AG
Tannwaldstrasse 86
CH-4600 Olten
Telephone +41 62 286 95 00
sales.ech@eao.com

**United Kingdom, Denmark,
Finland, Ireland, Norway, Sweden**
EAO Ltd.
Highland House
Albert Drive
Burgess Hill
GB-West Sussex RH15 9TN
Telephone +44 1444 236 000
sales.euk@eao.com