

Diaphragm Seal Piston Press. Switches

P1H

Mechanical single switch
Repeatability ± 2.0 % at constant temperature

Features

Mechanical pressure switches,
external setpoint adjustment

Adjustment ranges

0.1 ... 107 bar

Applications

Hydraulic and pneumatic power units,
Shipbuilding applications



Technical Data

Wetted parts:	
Diaphragm:	NBR Optional: FKM, PTFE
Process connection:	Aluminium, anodized Optional: stainless steel 1.4401
Repeatability:	± 2 % at constant temperature
Switching rate:	max. 20/min
Temperature range:	-30 °C... +70 °C
Protection class:	IP65
Material	
Housing:	Aluminium, anodized
Cap:	Steel, galvanized
Process connection:	1/4" NPT female thread Optional: 1/2" NPT female thread (P2)

Electrical connection:	Screw terminals and cable gland 1/2" NPT, cable diameter $\varnothing 7$... 12 mm
Electrical ratings and hysteresis:	A large variety of micro switches offers different electrical ratings and hysteresis for many applications.
Weight:	P1H-....: approx. 1.2 kg
Set point adjustment:	Turn the adjustment screw clockwise to increase the set point
Intrinsically safe:	The switches are designed for intrinsically safe applications. Please add "Exi" to your ordering details when placing an order. To comply with the intrinsically safe approval following max. ratings must not be exceeded: U _{max} = 28 V I _{max} = 50 mA
Approval:	NACE

Pressure Ranges

Pressure range code	Adjustment range [bar]		Max. operating pressure [bar]	Proof pressure [bar] (short term)	Max. hysteresis of switch types in bar (end of range)		
	Increasing press.	Decreasing press.			B	H, GH [bar]	K [bar]
30	0.1 ... 2.1	0.03 ... 2.0	91	137	0.14	0.06	0.17
85	0.4 ... 6.0	0.2 ... 5.8	91	137	0.50	0.17	0.58
340	0.8 ... 23.4	0.4 ... 23.0	91	137	1.50	0.41	1.83
600	2.9 ... 41.0	1.7 ... 40.0	91	137	2.00	1.17	2.42
1600	32.0... 107.0	27.0... 101.0	110	165	7.00	4.80	8.60

Diaphragm Seal Piston Press. Switches

P1H

Dimensions (mm / inch)

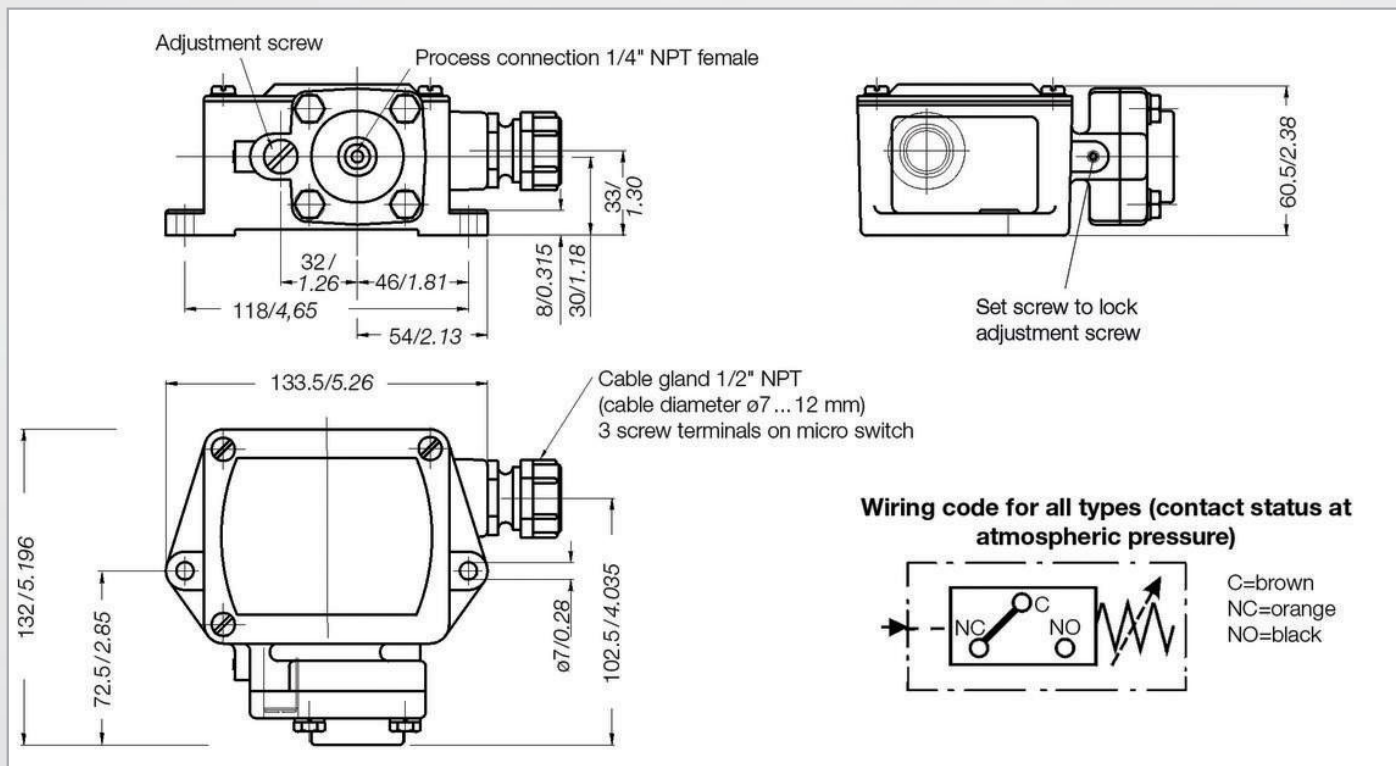

Electrical Ratings

Micro switch	Special features	Volt AC 50/60 Hz	Ind. load A	Res. load A	Volt DC	Ind. load A	Res. load A	Comments
H	Micro switch with silver contacts	125 250 480	10 10 3	10 10 3	6 to 28	0.50	0.5	Small hysteresis; High AC / low DC loads
GH	Micro switch with gold contacts for low voltage and low current	125	1	1	24	0.10	1.00	Small hysteresis
K, B	Micro switch with silver contacts K: with sealed plunger and stainless steel blade	125 250 480	10	10	12 24 250	10.00 5.00 0.03	10.0 6.0 0.2	Medium hysteresis; High AC and DC loads

Material / Options / Diaphragm

Material	Options	Diaphragm
()... Aluminium	(P2) 1/2" NPT female SS	() NBR
(SS) Stainless steel		(V) FKM
		(T) PTFE

Order Code

Example for order number

Type	Micro switch	Pressure range code	Material	Options	Diaphragm
P1H	H	85	SS	P2	V

Your order number

Type	Micro switch	Pressure range code	Material	Options	Diaphragm