



Joysticks

SERIES 67A Hall Effect Joystick

FEATURES

- Proportional output
- Shaft and panel seal to IP67
- Compact: 1-inch square flange
- Long operational life
- RoHS compliant

APPLICATIONS

- Medical
- Military vehicles and devices
- Mobile electronics for outdoor use



DIMENSIONS in inches (and millimeters)

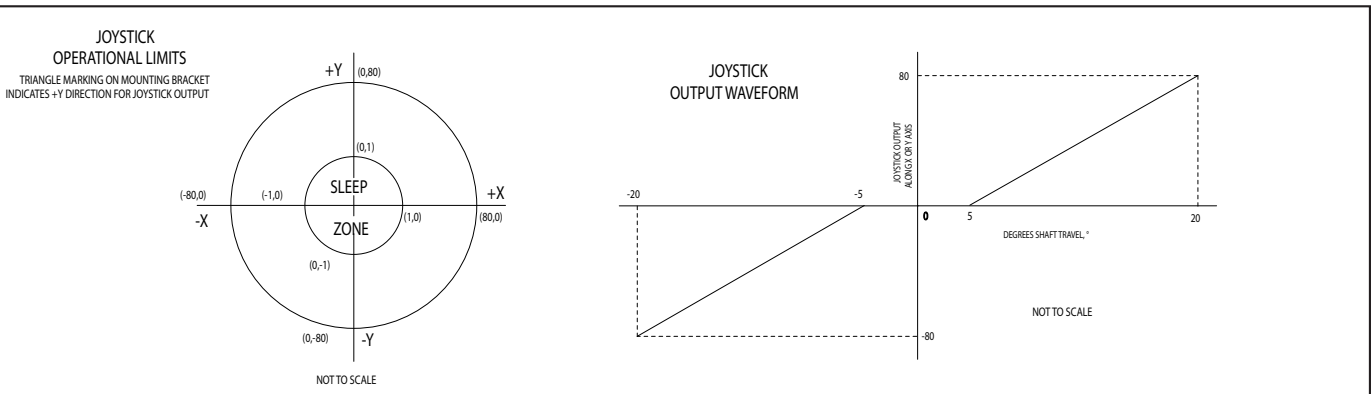
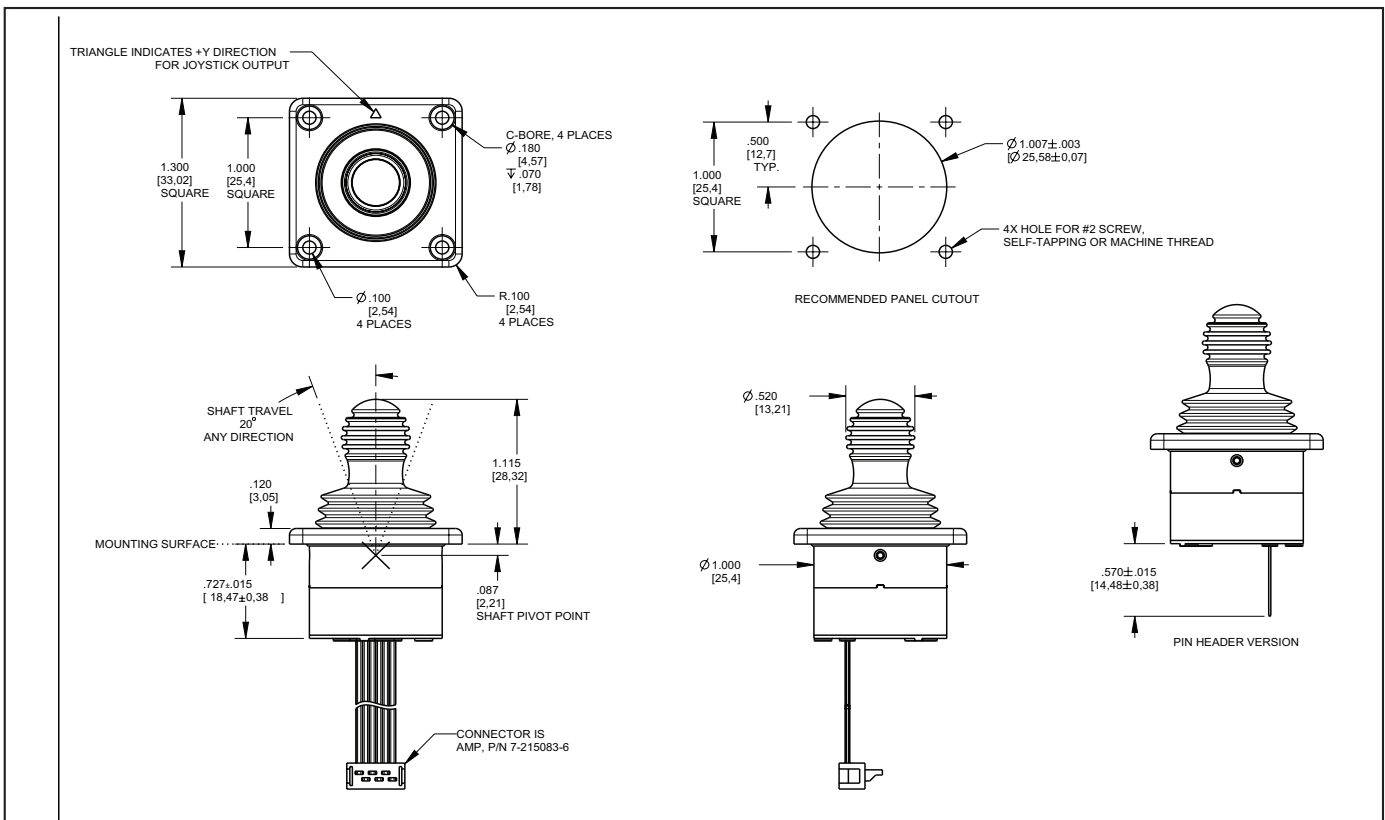

SPECIFICATIONS

Electrical Ratings

Supply Voltage (VVD): 3.3V ± 0.3V
High Level Input Voltage (VIH, Min): 0.7*VDD on SCL & SDA / 0.25*VDD+0.8 on Aln
Low Level Input Voltage (VIL, Max): 0.3*VDD on SCL & SDA / 0.15*VDD on Aln
Current Draw In Active Mode (IDD1): 3mA Maximum @ VDD = 3.3V
Current Draw In Sleep Mode (IDD2): 100uA Maximum @ VDD = 3.3V
Maximum Current Sunk By Any I/O Pin: 25mA
Leakage Current: ±5 nA Typ., ±125 nA Max
Low Level Output Voltage (VOL): 0.6V On INTn & SDA @ IOL = 6mA, @ VDD = 3.3V
Measurement Frequency (Active Mode): 50 Samples/Sec
Response Time, Active Mode (T1): 20ms*
Response Time, Sleep Mode (T2): 80ms*
Output @ Maximum Joystick Deflection (XMax, YMax): 80 Units
Output With Joystick Shaft Released (Center Position): (0,0)
Nominal Startup Time (TP, W): 300ms, Max

Physical & Mechanical Ratings

Vibration: Random, Tested per MIL-STD-810G, Method 514.6, Procedure I
Mechanical Shock: Tested per MIL-STD 202, Method 213B Test Condition A
Transit Drop: Tested per MIL-ST-810G, Method 516.6, Procedure II
Terminal Strength: 10 lbs. Minimum, Tested per MIL-STD-202, Method 211A
Push-Out Force: 60 lbs. Minimum
Pull-Out Force: 60 lbs. Minimum
Shaft Impact: 0.5 lbs. Weight dropped 20x from height of 1m
Shaft Side-Load: 45 lbs. Minimum
Mounting Torque: 3-5 in-lbs recommended, 8 in-lbs. Maximum
Joystick Life: 1 million cycles minimum**

Environmental Ratings

Seal: IP67, Tested per IEC 60529
Altitude: Tested per MIL-STD 202, Method 105C
Thermal Shock: Tested per MIL-STD 202, Method 107G
Operating High Temperature: +85°C, Tested per IEC 68-2-14, Test Na
Operating Low Temperature: -40°C, Tested per IEC 68-2-14, Test Na

Storage High Temperature: +100°C,

Tested per IEC 68-2-2, Method Ba

Storage Low Temperature: -55°C,

Tested per IEC 68-2-1, Method Aa

Humidity: Tested per MIL-STD 202, Method 103B

Humidity, 85/85: Tested per MIL-STD 202, Method 103B, 500 hours

Solar Radiation: Tested per MIL-STD 810G, Method 505.5, Procedure II

Chemical Resistance: Tested per ISO 16750-5

Dielectric: Tested per MIL-STD 202G, Method 301

Insulation Resistance: Tested per MIL-STD 202G, Method 302

EMC Ratings

Radiated Immunity: Tested per IEC 61000-4-3

Conducted Immunity: Tested per IEC 61000-4-6

Radiated Emissions: Tested per ANSI C63.4

Conducted Emissions: Tested per EN 55022

Electrostatic Discharge: Tested per IEC 61000-4-2

Power Frequency Magnetic Field: Tested per IEC 61000-4-8



Block Diagram

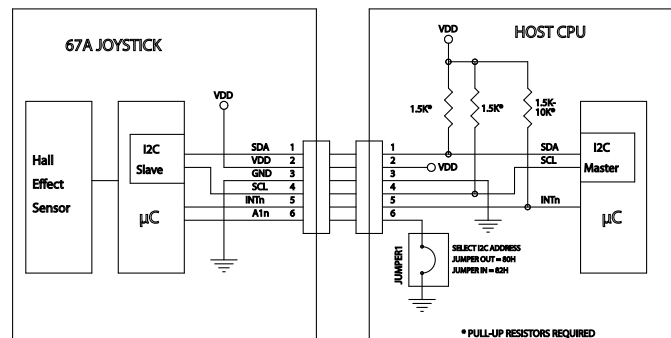

*Response time is the time from joystick movement to when new X,Y position data is available.

**One cycle is defined as a complete revolution of the shaft around the fixed perimeter, or one actuation in each of the 4 main directions, with return to center between each actuation.

ORDERING INFORMATION

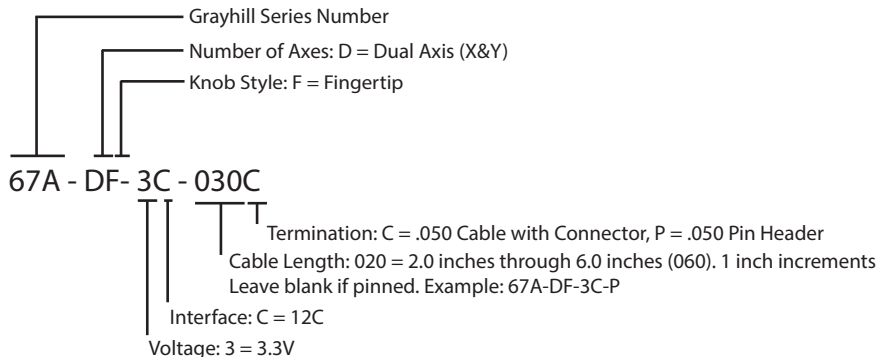

For prices and custom configurations, contact a local sales office, an authorized distributor, or Grayhill's sales department.