

Inductive Transducer in Metal Housing

11

Product group

A W E F

Application

The inductive transducer is a linear system for measuring travel. It can either be flanged to a solenoid or to any other object to be measured. The core, which can be moved within the coils, has to be connected to the object to be measured via the threaded pin. Special features of MSM transducers are high resolution, good linearity and long service life.

If the sensor is linked to a control electronics system and a proportional solenoid, a complete travel control system is created. Fastening is made by square flange. For applications under pressure, sealing between tube and the solenoid or valve is effected through o-ring provided by the customer.

Function

Function of the inductive transducer is based on the principle function of a differential transformer. The electronics integrated in the device supply the primary coil, evaluates voltage induced in the secondary coils and provides a defined output signal.

Construction characteristics

- Two designs with limiting frequency 20 Hz and 500 Hz
- Suitable for dry and pressure-tight applications
- Pressure-tight tube, designed for 350 bar static pressure
- Mounting by square flange
- Electrical connection and protection rating if mounted properly:
 - Connection with built-on plug by Messrs. Binder M12 x 1 – 713 series
 - Protection to DIN VDE 0470 / EN 60529 – IP 65 with sealed read-out potentiometer
- (Electronic) zero adjustment from outside
- Threaded rod for fastening the core with the measuring object
- EMC: EMC directive
- Version according to ATEX on request



Fig. 1: A WE F 004 A02

Technical data

A WE F 004	A01 A02 A03	A04 A05 A06
Measuring path (mm)	± 4	
Supply voltage (≡ V)	24 ± 10 %	
Polarity reversal power supply	yes	no
Current consumption (mA)	< 50	
Sensitivity $\left(\frac{\equiv V}{\text{mm}}\right)$	0,5 ± 1 %	
Output voltage (≡ V)	5,5 ... 9,5	
Linearity tolerance (%)	± 1	
Top limiting frequency (-3 dB) (Hz)	typ. 20	typ. 500
Reference temper. range (°C)	0 ... + 50	
Temperature drift (% / K)	typ. 0,05	
Load resistance (kΩ) Ausgangsspannung	> 5 Short circuit proof	

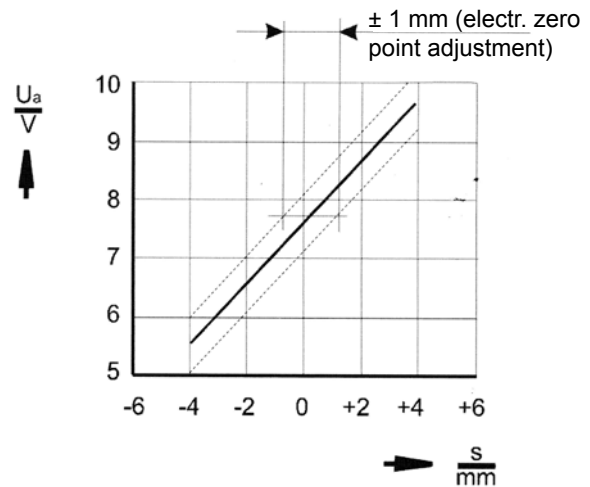

Fig. 2: Voltage vs stroke diagram for transducer with integrated electronic

Sensitivity

Sensitivity is the change in the output signal (ΔU) with reference to the change in the measuring path (Δs indicated in V/mm).

$$\text{Sensitivity} = \frac{\Delta U}{\Delta s}$$

Linearity error

The Linearity error indicates the deviation of the output signal from the ideal graph in per cent.

$$\text{deviation}_{\text{Lin}} = \frac{|(U_{\text{actual}} - U_{\text{nominal}})|}{U_{\text{voltage stroke}}} \times 100 \%$$

Temperature drift

Temperature drift indicates in per cent the deviation of the output signal per degree of temperature change (shown in % / K).

$$\text{deviation}_{\text{temp.}} = \frac{|(U_{\text{temp}} - U_{20^\circ \text{C}})|}{U_{\text{voltage stroke}} \times |\Delta T|} \times 100 \%$$

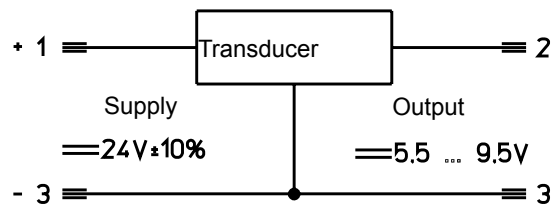



Fig. 3: Block diagram

Information and remarks concerning European directives can be taken from the correspondent information sheet which is available under *Produktinfo.Magnet-Schultz.com*.

Note on the RoHS Directive

According to our current state of knowledge the devices pictured in this document do not contain any substances in concentration values or applications for which putting into circulation with products manufactured from them is prohibited in accordance to RoHS.

Please make sure that the described devices are suitable for your application. Supplementary information concerning its proper installation can be taken also from the  -Technical Explanation, the effective DIN VDE0580 as well as the relevant specifications.

This part list is a document for technically qualified personnel.

The present publication is for informational purposes only and shall not be construed as mandatory illustration of the products unless otherwise confirmed expressly.

Dimensions sheet

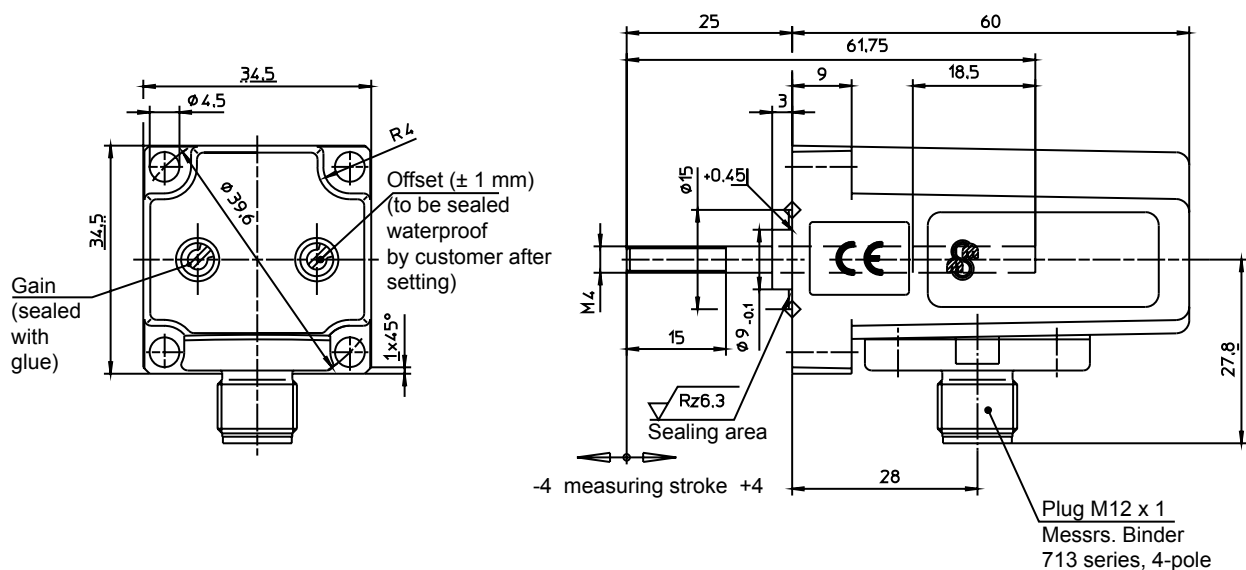

Types	x_1	y_1
A WE F 004 A01	61.75	18.5
A WE F 004 A04	68.50	28.0

Fig. 4: Types A WE F 004 A01 (cut-off frequency 20 Hz)
A WE F 004 A04 (cut-off frequency 500 Hz)

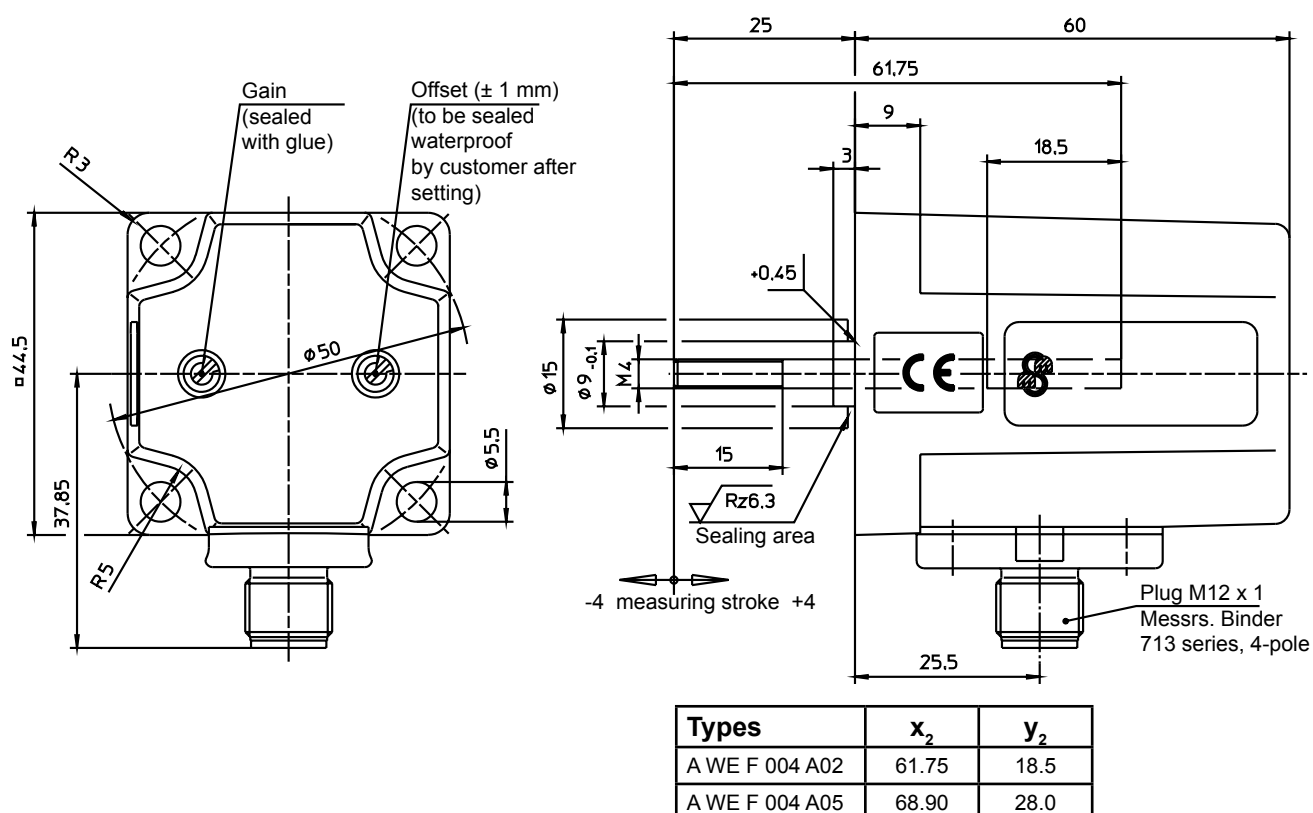

Types	x_2	y_2
A WE F 004 A02	61.75	18.5
A WE F 004 A05	68.90	28.0

Fig. 5: Types A WE F 004 A02 (cut-off frequency 20 Hz)
A WE F 004 A05 (cut-off frequency 500 Hz)

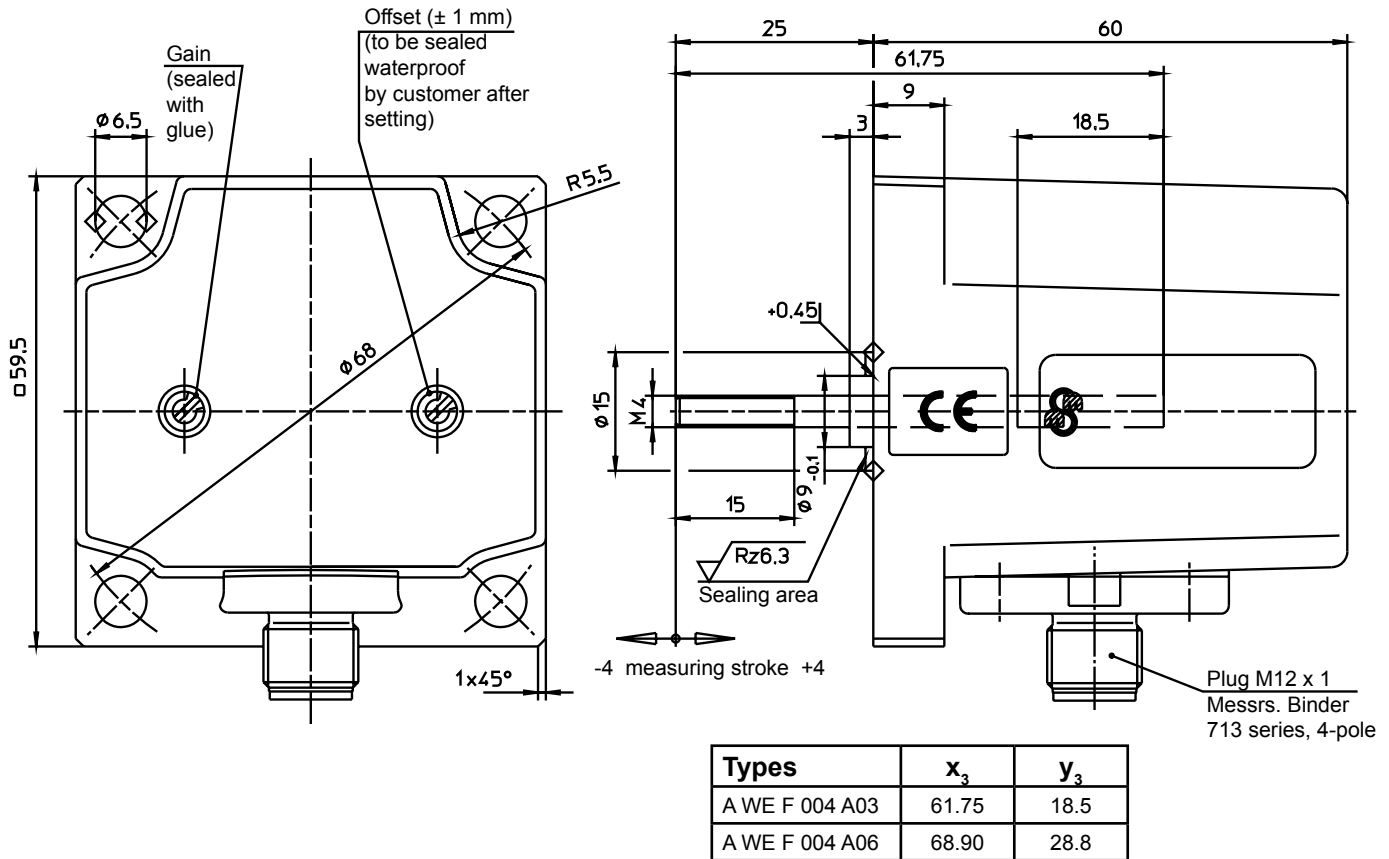
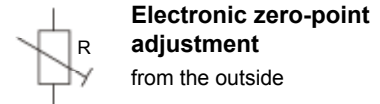
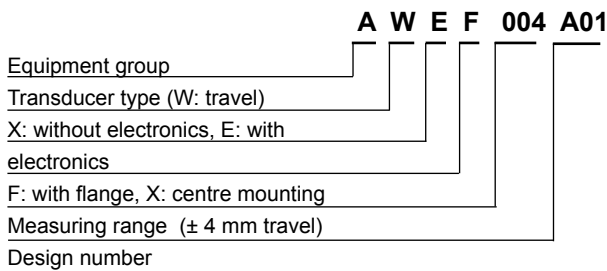

Fig. 6: Types A WE F 004 A03 (cut-off frequency 20 Hz)
A WE F 004 A06 (cut-off frequency 500 Hz)



Type code



Order example

Type A WE F 004 A01
Voltage === 24 V DC

Specials designs

Please do not hesitate to ask us for application-oriented problem solutions. In order to find rapidly a reliable solution we need complete details about your application conditions. The details should be specified as precisely as possible in accordance with the relevant -Technical Explanations.

If necessary, please request the support of our corresponding technical office.