

DC Solenoid Valve for Pneumatics

3

Product group

V PK M 007

Function

- 2/2 NO; 2/2 NC; 3/2 NC
- Armature space pressure tight up to 40 bar static pressure
- For DC

Construction

- Miniature valve, compact construction
- Fastening via threaded bores on the rear side
- Insulation materials of the excitation winding correspond to thermal class B
- Electrical connection via solder pin
- Protection class according to DIN VDE/DIN EN 60529 IP 00
- Serial mounting possible

Options

- Please contact us for application related solutions
- Modifications and special designs as well as accessories such as functions 3/2 NO

Standards

- Design and testing according to DIN VDE 0580
- Production according to ISO 9001



Fig. 1: V PK M 007 K00 A03/A04

Technical data

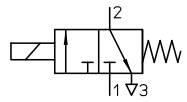
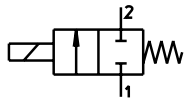
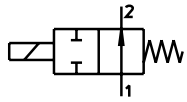
V PK M 007 K00	A01	A03	A04	
Voltage U_N	24 VDC \pm 10%			
Operating mode with single mounting	S3 (50%)			
Rated current I_{20}	46 mA			
Rated power P_{20}	1 W			
Operating temperature	+ 5 °C ... + 50°C			
Medium	unoiled filtered air			
Pressure range	2-5 bar	2-8 bar		
Nominal width	P-seat	0,5 mm	0,55 mm	0,4 mm
	R-seat	0,8 mm effective	---	---
Normal rated flow	Q_N 1-2	≥ 6 l/min	≥ 7 l/min	$\geq 3,5$ l/min
	Q_N 2-3	≥ 12 l/min	---	---
Function	3/2 NC	2/2 NC	2/2 NO	
Circuit diagram				

Notes on the tables

The pneumatic values indicated in the tables refer to 90% of the rated voltage ($U_N = \text{---} 24$ V) and to the normal operating temperature.

Due to natural dispersion these pneumatic values may deviate by approx. 10% from the values indicated in the tables.

The normal operating temperature is based on:

- Mounting on heat-insulating base
- Rated voltage $\text{---} 24$ V
- Operating mode S3 (50%)
- Reference temperature 20° C

These data apply for the medium of compressed air.

Rated voltage

Rated voltage $\text{---} 24$ V, an adaptation of the exciter coil to a rated voltage of max. $\text{---} 36$ V is possible on request.

The devices correspond to protection class III. Electrical equipment of protection class III may be only connected to low voltage systems (PELV, SELV)(IEC 60364-4-41).

We recommend using compressed air corresponding to DIN ISO 8573/1 class 3

Information and remarks concerning European directives can be taken from the correspondent information sheet which is available under *Produktinfo.Magnet-Schultz.com*.

Note on the RoHS Directive

According to our current state of knowledge the devices pictured in this document do not contain any substances in concentration values or applications for which putting into circulation with products manufactured from them is prohibited in accordance to RoHS.

Please make sure that the described devices are suitable for your application. Supplementary information concerning its proper installation can be taken also from the  -Technical Explanation, the effective DIN VDE0580 as well as the relevant specifications.

This part list is a document for technically qualified personnel.

The present publication is for informational purposes only and shall not be construed as mandatory illustration of the products unless otherwise confirmed expressively.

Dimension table

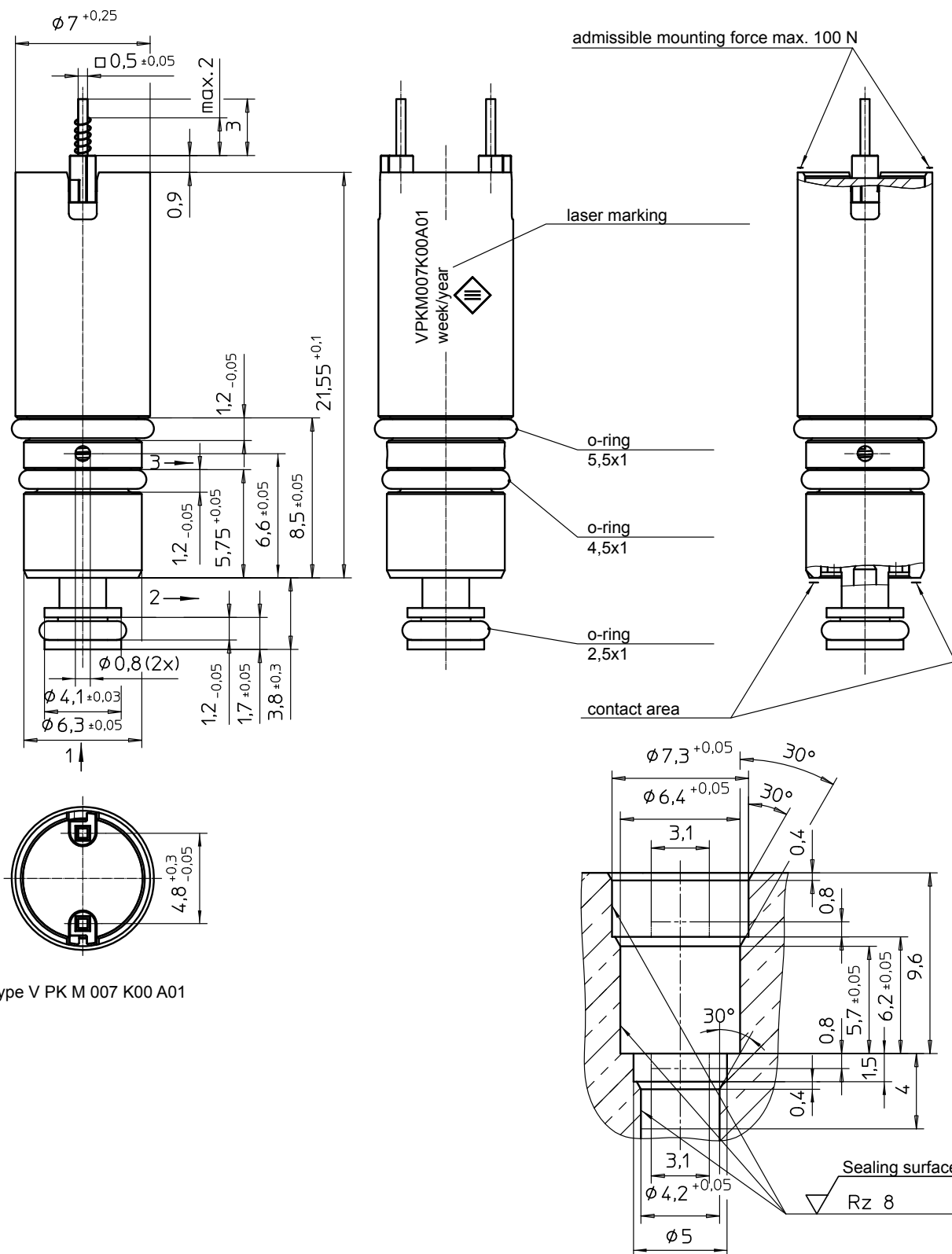

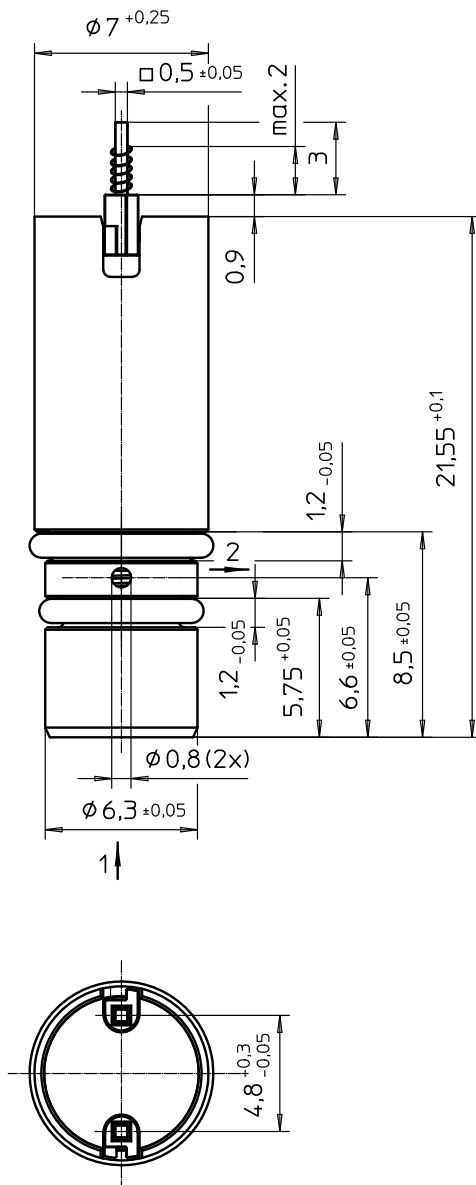

Fig. 4: Type V PK M 007 K00 A03/A04

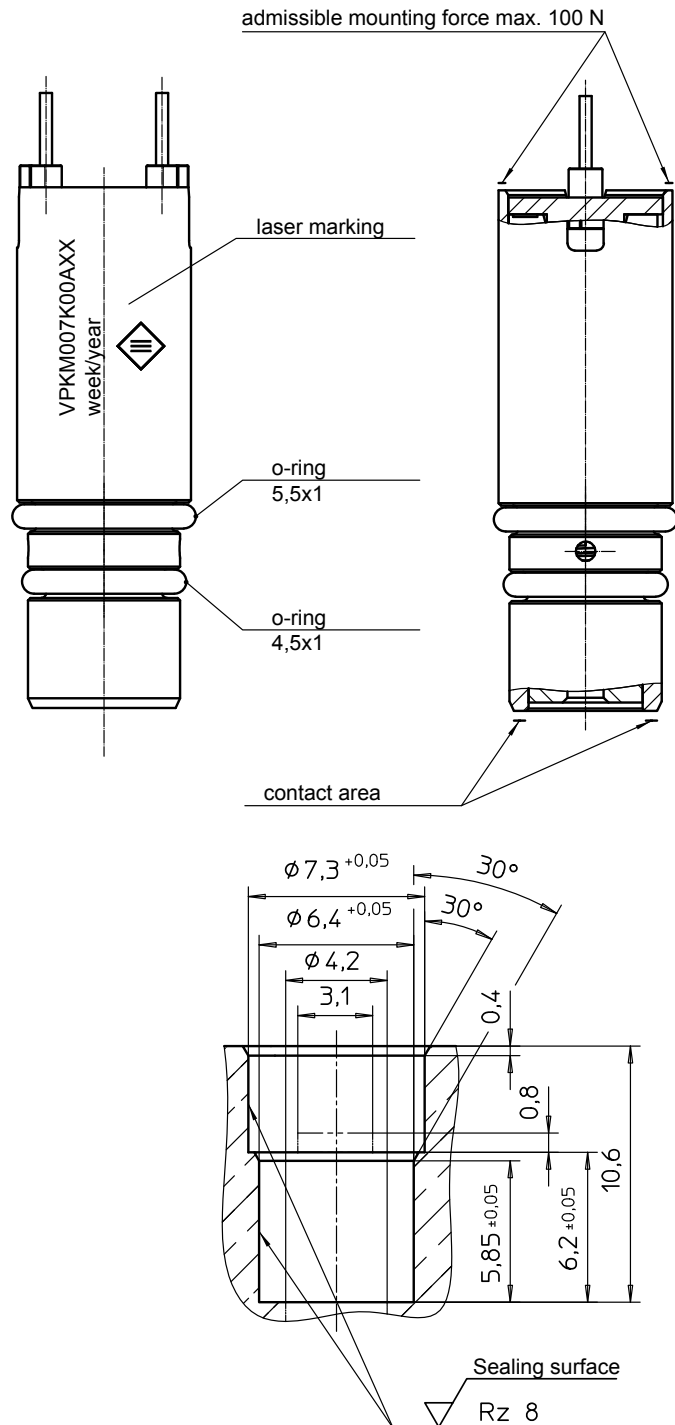

Fig. 5: Connection diagram for V PK M 007 K00 A03/A04

Example

Type	V PK M 007 K00 A03
Voltage	== 24 V DC
Operating mode	S3 (50 %)

Specials designs

Please do not hesitate to ask us for application-oriented problem solutions. In order to find rapidly a reliable solution we need complete details about your application conditions. The details should be specified as precisely as possible in accordance with the relevant -Technical Explanations.

If necessary, please request the support of our corresponding technical office.