

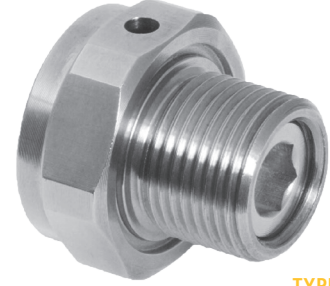

TYPE E



TYPE D

781



**781 Breather / Drain Plug, Globally Approved, Explosive Atmosphere Cable / Conduit Accessory**

- 781E for Ex e use
- 781D for Ex d use
- Drains equipment susceptible to moisture collection
- Enables equipment to breathe
- General purpose / industrial version available
- Nylon Ex e only version available (-20°C to +60°C)
- -60°C to 130°C (metallic versions)
- Globally marked, IECEx, ATEX & cCSAus

**781D**

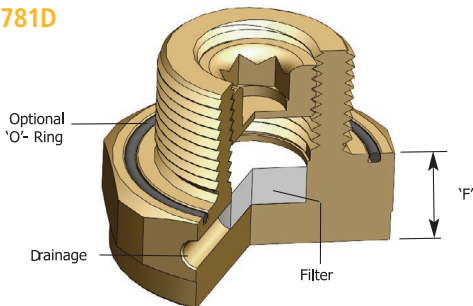

**781E**

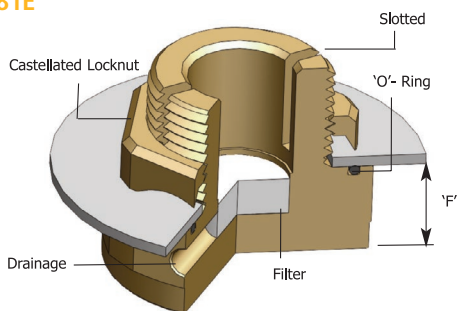

**TECHNICAL DATA**

<b>Design Specification</b>	BS 6121:Part 1:1989
<b>Enclosure Protection</b>	IK10 to IEC 62262 (20 joules) Brass & Stainless Steel Only
<b>ATEX Certificate</b>	SIRA 10 ATEX 1307U
<b>Code of Protection</b>	781D: Ⓔ II 2G Ex d IIC Gb, II 1D Ex ta IIIC Da 781E: Ⓔ II 2G Ex e IIC Gb, II 1D Ex ta IIIC Da
<b>Compliance Standards</b>	EN 60079-0,1,7,31
<b>IECEx Certificate</b>	IECEx SIR 10.0149U
<b>Code of Protection</b>	781D: Ex d IIC Gb, Ex ta IIIC Da 781E: Ex e IIC Gb, Ex ta IIIC Da
<b>Compliance Standards</b>	IEC 60079-0,1,7,31
<b>cCSAus Certificate</b>	1055233
<b>Code of Protection</b>	781D: Ex d IIC, Class I, Zone 1 AEx d IIC; Class I Div 1, Groups A,B,C,D IP66, Enclosure Type 4X 781E: Ex e II, Class I, Zone 1, AEx e II IP66, Enclosure Type 4X
<b>Compliance Standards</b>	CSA C22.2 No 0-10, 0.5, 30, 94; CSA C22.2 60079-0,1,7, E61241-1-1, UL50, 1203, UL60079-0,1,7
<b>UL Certificate</b>	E253914
<b>EAC Certificate</b>	TC RU C-GB-AA87.B.00487
<b>UkrSEPRO</b>	UA.TR.047.C.0644-15
<b>CCOE / PESO (India) Certificate</b>	P333688
<b>INMETRO Certificate</b>	TÜV 12.1330U
<b>RETIE Approval</b>	03866
<b>NEPSI Certificate</b>	GY118.1248U
<b>RETIE Approval</b>	03866
<b>Marine Approvals</b>	LRS: 01/00173
<b>Continuous Operating Temperature</b>	781D: -60°C to +130°C 781E: -60°C to +130°C (-20°C to +60°C Nylon)
<b>Ingress Protection Rating**</b>	781D: IP66 (when fitted with CMP sealing accessories) 781E: IP66 (with 'O' ring interface seal and lock nut as standard)
<b>Available Materials</b>	Brass, Nickel Plated Brass, Aluminium, Stainless Steel, Nylon (781E only)
<b>Accessories Included (781E only)</b>	Integral Entry Thread equipment interface 'O' ring seal, Castellated Locknut

The 781D can be used with enclosures up to 30 litres for group IIB gases and enclosures up to 2.5 litres for group IIC gases  
 \*\* When CMP installation accessories are used (781E). Refer to page 7 or www.cmp-products.com for further information.

**HOW TO ORDER**

e.g. 781 - D - M - 3 = Ex d - M25  
 e.g. 781 - E - M - 3 = Ex e - M25

Other Thread Variations are available on request. For further information on ordering please refer to page 150.

The CMP 781E range of Increased Safety type 'e' breather / drain plugs have been tested together with CMP serrated washers to ensure that in areas that are subject to vibration the plug does not suffer from self-loosening and in advertently fall out of the enclosure. Serrated washers are not included as standard but can be ordered separately.

**Product Selection Table**

Ordering Reference (781D)	Ordering Reference (781E)	Thread Size	Minimum Thread Length	Protrusion Length "F"	Across Flats Dimension	Across Corners Dimensions	Max Installation Torque (Nm)
781DM2	781EM2	M20 x 1.5	15.0	12.7	30.0	33.0	7
781DM3	781EM3	M25 x 1.5	15.0	12.7	36.0	39.6	10
781DT1	781ET1	½" NPT	19.9	12.7	30.0	33.0	7
781DT2	781ET2	¾" NPT	20.2	12.7	36.0	39.6	10

All dimensions shown are in millimetres unless otherwise stated