

Industrial Obstacle Marking Beacons

VS-205LED-OM

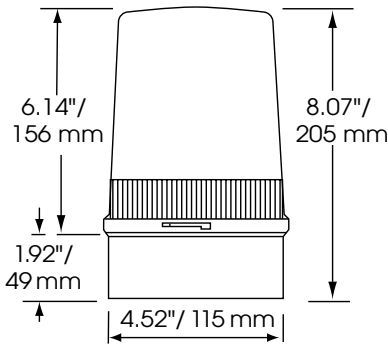

- Rated for continuous use
- Long life Red LEDs
- Suitable for surface, conduit box or wall mounting
- Optional wall bracket and dome guard available
- 360° light output around the vertical axis
- Dustproof and Weatherproof



2 x 0.196\"/>

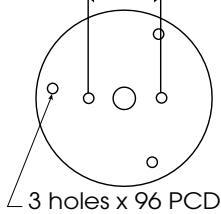

The VS-205LED-OM red LED obstacle marking light is available in two candela ratings: 10 and 32 Cd and is available in flashing (60/90 FPM) or continuous steady burn mode. This signal can be used with a photocell control if desired. The UV stable polycarbonate housing and base are secured with a stainless steel sealing band.

The VS-205LED-OM offers a surface, conduit box or wall mount base. These models are suitable for marking fixed objects/obstructions where the object is less extensive and the overall height above the ground is less than 147 ft./ 45 m.

ORDERING INFORMATION

MODEL	VOLTAGE	LIGHT SOURCE	CURRENT	CANDELA
VS-205LED-OM10-24*	24VAC/DC	LED	0.33 A	10Cd
VS-205LED-OM10-48S	48VAC/DC	LED	0.16 A	10Cd
VS-205LED-OM10-230S	230VAC/DC	LED	0.04 A	10Cd
VS-205LED-OM32-24*	24VAC/DC	LED	0.50 A	32Cd
VS-205LED-OM32-48S	48VAC/DC	LED	0.24 A	32Cd
VS-205LED-OM32-230S	230VAC/DC	LED	0.05 A	32Cd

* Include (S) Steady or (F) Flashing mode

OPTIONAL ACCESSORIES

- VS-DG-L Dome Guard, Large
- VS-MB-L Mounting Bracket, Large



1 Year
Warranty



0.6 kg
1.32 lbs



-20° to 45°C
-4° to 113°F



66



60/90



50/60 Hz