

VS-107LED

- Rated for continuous use
- LED long life
- Low current consumption
- Suitable for surface or wall mounting
- Optional wall bracket and dome guard available
- 360° light output around the vertical axis
- Dustproof and Weatherproof

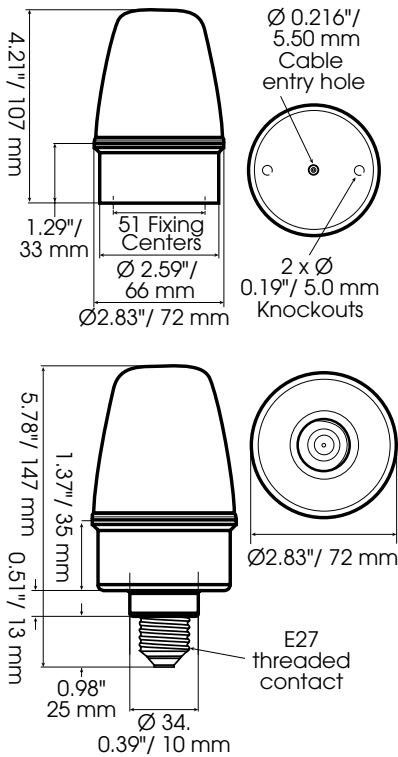

Model VS-107LED is field selectable to either flashing or continuous steady burn mode. This model also allows a third connection option to switch from a pre-set steady burn mode to flashing (Not available on the LEDE model).

Model VS-107LEDE offers an Edison screw base. This mounts allows for quick installation in an area using existing electrical lighting points and avoids any additional wiring.

These models are suitable for light commercial and industrial applications.

ORDERING INFORMATION

MODEL	VOLTAGE	LIGHT SOURCE	CURRENT
VS-107LED-08-20*	8-20VAC/DC	8 SMT LEDs	430 mA ¹
VS-107LED-20-30*	20-30VAC/DC	8 SMT LEDs	110 mA ²
VS-107LED-35-85*	35-85VAC/DC	8 SMT LEDs	call factory
VS-107LED-85-280*	85-280VAC/40-380VDC	8 SMT LEDs	35 mA ³

LEDE VERSION

VS-107LEDE-85-280*	85-280VAC/40-380VDC	8 SMT LEDs	35 mA
--------------------	---------------------	------------	-------

¹ at 12VDC, ² at 24VDC, ³ at 230VAC

* Indicates color: (A) Amber, (G) Green or (R) Red

OPTIONAL ACCESSORIES

- VS-DG-S Dome Guard, Small
- VS-MB-S Mounting Bracket, Small

Available in the following colors:



1 Year
Warranty



0.11 kg 0.24 lbs VS-107LED
1.15 kg 2.53 lbs VS-107LEDE



-25° to 55°C
-13° to 131°F



65



160



50/60 Hz