

Combination - Beacon Sounder eXL07 (CU1)

- ▶ Zone 1, Zone 2
- ▶ Ex de IIB T3
- ▶ ATEX approved, Ex II 2 G
- ▶ BASEEFA certified
- ▶ Protection IP66 / IP67
- ▶ Certified temperature: -50 °C to +50 °C
- ▶ Up to 116 dB(A)*
- ▶ 27 Tones, user selectable
- ▶ 24 VDC version two stage alarm
- ▶ Tones comply with UKOOA/PFEER guidelines
- ▶ Integral volume control
- ▶ GRP corrosion-free flamepath
- ▶ Ratcheted swivel mounting stirrup
- ▶ Stainless steel fixtures
- ▶ Tapered flamepath



Introduction

This range of beacon/sounder units, intended for use in potentially explosive gas atmospheres, has a sound output of up to 116 dB(A) and tube energy of 10 joules (beacon). It is suitable for use in the harsh environmental conditions found offshore and onshore in the oil, gas and petrochemical industries.

The flamepaths, flare and body are manufactured from a UV stable glass reinforced polyester. Stainless steel screws and mounting stirrup are incorporated to ensure a corrosion-free product.

A tapered flamepath is used to overcome the problems of assembly of parallel spigot flamepaths.

Used on a oil platform

For connection to an analogue telephone system with an integrated telephone connecting relay.



Technical specifications

Certification	
ATEX	Cert. no. Basefa 04ATEX0273X Certified to: EN60079-0, EN60079-1, EN60079-7 Ex II 2G, Ex de IIB T3 Gb
Material	Body, flares & covers: Glass Reinforced Polyester (GRP) Lens: Glass Guard fitted as standard Cover screws & mounting strap: Stainless steel
Finish	red
Certified Temp	Standard unit: -50 °C to +50 °C (CU1-S & CU1-SP)
Weight	6.5 kg approx.
Ingress Protection	IP66 and IP67
Entries	Up to 2x M25, 2x M25 ISO, 2x M20 with 1/2" NPT adaptor or 2x M25 with 3/4" NPT adaptors into termination (Exe) chamber.
Terminals	8x 4.0 mm ²
Relay Initiate:	Available on all versions – operates with 24 V d.c. initiate supplies only
Mounting	Stainless steel bracket with ratchet facility
Labels	Duty and tag label option to customer's requirements
Tube Energy	10 Joules
Sound Output	Sound Standard unit: 116 dB(A) ± 3 dB(A) (tone dependent)
Tone Selection	27 user selectable tones

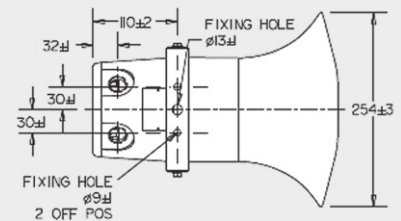
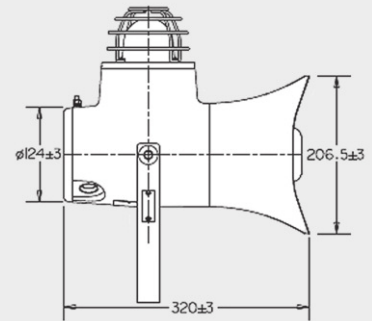
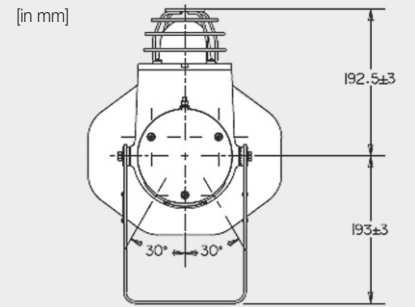

Order information

Old p/n	Name	Voltage	Color	Current	Order Code
225 827 02	Beacon Sounder eXL07	230 VAC	red	172 mA	CU1SB230T06RTN1BR
225 827 03	Beacon Sounder eXL07	230 VAC	amber	172 mA	CU1SB230T06ATN1BR
225 833 02	Beacon Sounder eXL07	24 VDC	red	1680 mA	CU1SPB024T06RTN1BR
225 833 03	Beacon Sounder eXL07	24 VDC	amber	1680 mA	CU1SPB024T06ATN1BR
225 887 02	Beacon Sounder eXL07 with tel. relay	230 VAC	red	172 mA	CU1SB230T06RTT2BR
225 887 03	Beacon Sounder eXL07 with tel. relay	230 VAC	amber	172 mA	CU1SB230T06ATT2BR
225 883 02	Beacon Sounder eXL07 with tel. relay	24 VDC	red	1680 mA	CU1SPB024T06RTT2BR
225 883 03	Beacon Sounder eXL07 with tel. relay	24 VDC	amber	1680 mA	CU1SPB024T06ATT2BR

Subject to change without notice · Printout 12/13