

# Dual frequency strobe light STZ3

**Comax**  
Signaltechnik

## General information

Efficient strobe light with dual frequency. High degree of protection IP65.

For applications in the machine and process industry, for cable car operations or in building control.

## Technical data

Dimensions	Ø 100mm x 150mm
Case	PC
-colour	black
Lens	PC
-colours	red, amber, yellow, green, blue, clear
Temperature range	-25°C up to +50°C
Construction	Bayonet with anti-tamper locking screw
Operation	continuous
Installation	Surface, wall, stand
Connection	Cable entry through bottom Ø 8mm or on side M20
Degree of protection	IP65 according to EN60529
Strobe intensity	5 Joule, 1Hz or 2Hz
Life cycle	After 5x10 <sup>6</sup> strobes reduction of the light output to 70%
Weight	325g

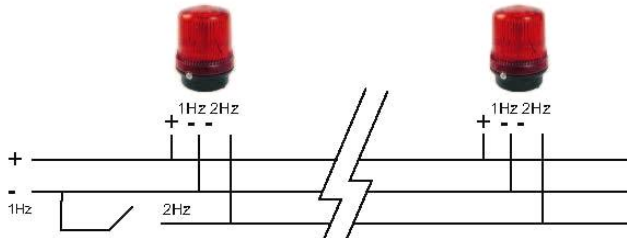
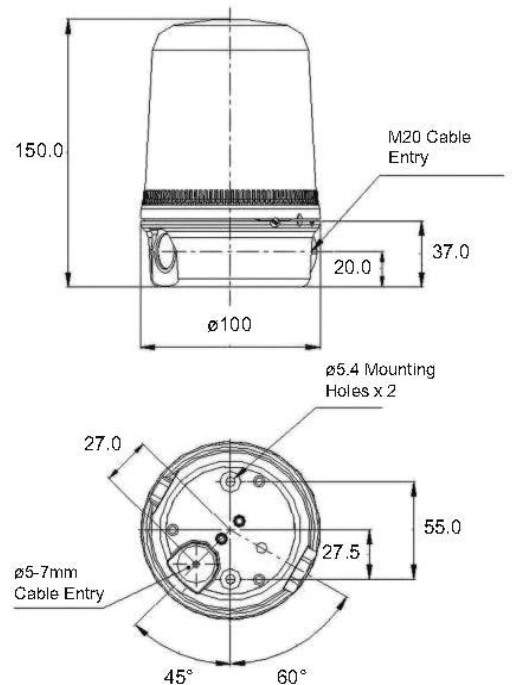

All dimensions in mm.

## Order data

No. of article	Nominal tension	Light output	Current consumption
STZ3.012.3*	12VDC	5J, 1Hz or 2Hz	500mA
STZ3.024.3*	24VDC	5J, 1Hz or 2Hz	250mA
STZ3.048.3*	48VDC	5J, 1Hz or 2Hz	175mA

## Lens colours

1 = red, 2 = amber, 3 = yellow, 4 = green, 5 = blue, 7 = clear

## Options

Wall mounting angle, stand (140mm)

Technical modifications without prior notice



**Comax**  
Signaltechnik

Comax Industrielle Signaltechnik AG, Römerstrasse 6/Postfach, CH-4512 Bellach/Schweiz  
Tel +41-(0)32-617 31 41 Fax +41-(0)32-617 31 40 e-mail: [mail@comax.ch](mailto:mail@comax.ch) internet: [www.comax.ch](http://www.comax.ch)

E\_STZ3\_REV0\_24\_01\_2013