

# Strobe light STR3

**Comax**  
Signaltechnik

## General information

Efficient strobe light with a modern design. Also available as model for synchronous operation. Degree of protection IP65.

For applications in the machine and process industry or in building control.

## Technical data

Dimensions	Ø 100mm x 150mm
Case	PC
-colours	black
Lens	PC
-colours	red, amber, yellow, green, blue, clear
Strobe intensity	5 Joule
Frequency	1Hz
Temperature range	-25°C up to +50°C
Construction	Bayonet with anti-tamper locking screw
Operation	continuous
Installation	surface, wall, stand
Connection	Cable entry through bottom Ø 5-7mm or on side M20
Degree of protection	IP65 according to EN60529
Weight	370g

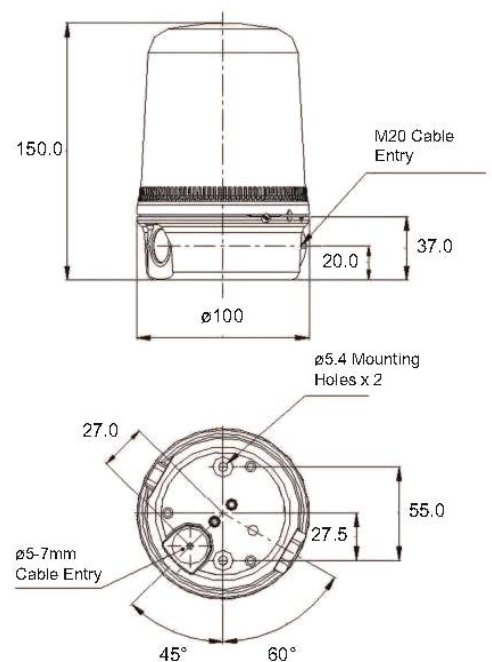

All dimensions in mm.

## Order data

No. of article	Nominal tension	Light output	Current consumption
STR3.012.3*	12VAC/VDC	5J	600mA/500mA
STR3.024.3*	24VAC/VDC	5J	300mA/250mA
STR3.048.3*	48VAC/VDC	5J	250mA/175mA
STR3.115.7*	115VAC 50/60Hz	5J	70mA
STR3.230.7*	230VAC 50/60Hz	5J	35mA

## Lens colours

1 = red, 2 = amber, 3 = yellow, 4 = green, 5 = blue, 7 = clear

## Options

Wall mounting angle, stand (140mm)

Model for synchronous operation (STS)

Technical modifications without prior notice



**Comax**  
Signaltechnik

Comax Industrielle Signaltechnik AG, Römerstrasse 6/Postfach, CH-4512 Bellach/Schweiz  
Tel +41-(0)32-617 31 41 Fax +41-(0)32-617 31 40 e-mail: [mail@comax.ch](mailto:mail@comax.ch) internet: [www.comax.ch](http://www.comax.ch)