

LED Signal light L101H

Comax
Signaltechnik

General information

Compact signal light with steady or flashing mode. LED technology. Degree of protection IP66.

For applications on machines or in buildings.



Technical data

Case	ABS
-colour	red (RAL3000)
Lens	PC
-colour	clear
LED	24 high power LED's
-colours	red, amber, green, blue, white
Intensity	120cd (white LED)
Signal	steady or flashing
Frequency	2 Hz
Temperature range	-25°C up to +55°C
Relative humidity	90% at 20°C
Operation	continuous
Installation	surface mount
Cable entry	knock-out holes for M20 cable gland
Connection	Terminals for cables 0,5-4.0mm ²
Degree of protection	IP66 according to EN60529
Weight	0,2kg
Approvals	UL-Approval (on request) GOST-R: POCC GB.JB05.B02228

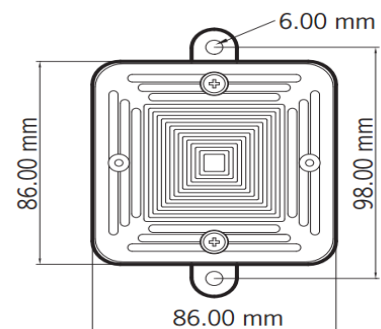
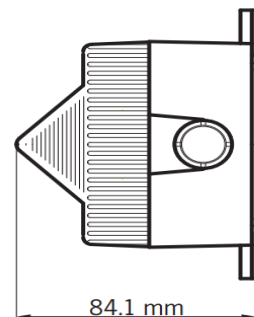

Order data

Article number	Nominal tension	Current
L101H.024.2*	10-30VDC	155mA
L101H.230.7*	90-260VAC 50/60Hz	35mA

Colours LED 1= red, 2= amber, 4= green, 5=blue, 6=white

Option Tropicalisation available on request
Version 90-260VAC/DC on request

Technical modifications without prior notice



Comax
Signaltechnik

Comax Industrielle Signaltechnik AG, Römerstrasse 6/Postfach, CH-4512 Bellach/Schweiz
Tel +41-(0)32-617 31 41 Fax +41-(0)32-617 31 40 e-mail: mail@comax.ch internet: www.comax.ch