

Small hooter lift-alarm KHL4

Comax
Signaltechnik

General information

Compact acoustic alarm as elevator alarm. Indoor mounting.



Technical data

Case	ABS, shock-resistant
Colour	light grey
System or protection	IP32 according to EN 60529
Temperature range	-15°C to +50°C
Duty cycle	continuous operation
Cable:	
-gland	Ø 12 mm
-lead	surface or flush mounting
-connection	conductor up to 1,5 mm ²
Weight	approx 0.18 kg

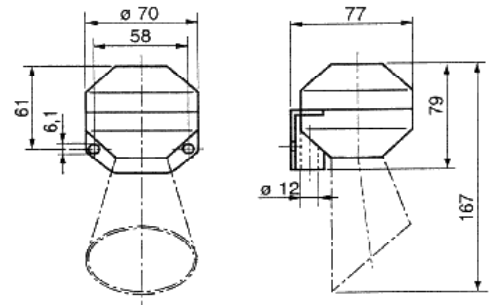

Order data

Item number	Rated voltage	Sound intensity level	Current consumption	Type
KHL4.006.2	6 VDC	approx 83 dB(A), 1m	45 mA	without flare
KHL4.012.2	12 VDC	approx 83 dB(A), 1m	70 mA	without flare
KHL4.024.2	24 VDC	approx 83 dB(A), 1m	70 mA	without flare

Subject to change without prior notice



Comax
Signaltechnik

Comax Industrielle Signaltechnik AG, Römerstrasse 6/Postfach, CH-4512 Bellach/Schweiz
Tel +41-(0)32-617 31 41 Fax +41-(0)32-617 31 40 e-mail: mail@comax.ch internet: www.comax.ch

E_KHL4_REV0_18_02_2013