

TA3 MECHANICAL WALL-MOUNTED THERMOSTAT

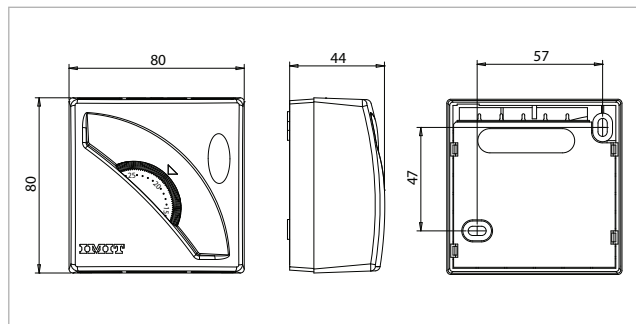

TA3 is a mechanical wall thermostat with saturated steam expansion tank, ideal for regulating home or office temperature. It is available in LED versions, without LED, ON / OFF (to turn off the thermostat without turning the knob), Summer / Winter (to connect and regulate the air conditioning or heating system). This thermostat also offers the possibility to limit or block the set temperature, through the installation of an optional switch under the cover.

Electrical contact capacity = 16(2,5) A / 250 Vac
 Regulation range = 5°±30°C
 Differential = 1K
 Insulation class = II
 Protection rating = IP20
 Max. tolerance temperature = 50°C
 Connection = 2 wires
 Output = changeover switches
 Operating mode: On/Off or Summer/Winter
 System: heating/air conditioning
 Certifications: CE, ENEC03, EAC

Code	Article	Description	Pack.
546070	TA3	3-contact thermostat	20
546030	TA3-A	3-contact thermostat-LED indicator light	20
546010	TA3-B	3-contact thermostat - LED indicator light - ON / OFF switch	20
546230	TA3-C	2-contact thermostat - LED indicator - summer winter switch	20
000071	SWITCH	Switch for knob lock	o.r.
004095	BOTTOM PIECES	Bottom pieces for TA3 in black	o.r.

TA5 MECHANICAL WALL-MOUNTED THERMOSTAT

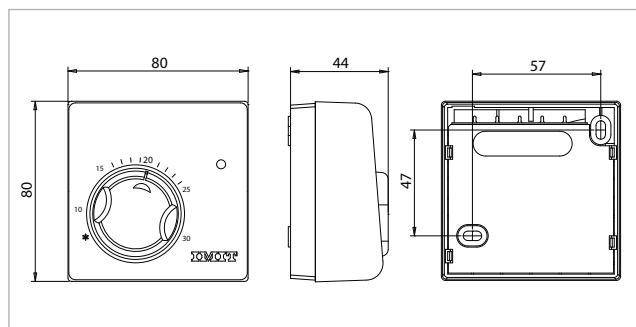

TA5 is a mechanical wall thermostat with saturated steam expansion tank, ideal for regulating home or office temperature. It is available in LED versions, without LED, ON / OFF (to turn off the thermostat without turning the knob), Summer / Winter (to connect and regulate the air conditioning or heating system). This thermostat also offers the possibility to limit or block the set temperature, through the installation of an optional switch under the cover. Thanks to the new external ergonomic knob, temperature regulation is simple and accessible to everyone.

Electrical contact capacity = 16(2,5) A / 250 Vac
 Regulation range = 5°±30°C
 Differential = 1K
 Insulation class = II
 Protection rating = IP20
 Max. tolerance temperature = 50°C
 Connection = 2 wires
 Output = changeover switches
 Operating mode: On/Off or Summer/Winter
 System: heating/air conditioning
 Certifications: CE, ENEC03, EAC

Code	Article	Description	Pack.
546770	TA5	3-contact thermostat	20
546730	TA5-A	3-contact thermostat-LED indicator light	20
546710	TA5-B	3-contact thermostat - LED indicator light - ON / OFF switch	20
546750	TA5-C	2-contact thermostat - LED indicator - summer winter switch	20
000071	SWITCH	Switch for knob lock	o.r.
004095	BOTTOM PIECES	Bottom pieces for TA5 in black	o.r.