



- CV600 -

- CV630 -

- CV650 -

**Low cost single rod vibrating level switches
for all kinds of dry granular solids**

Purpose

The **CV600/CV630/CV650** are vibration type level switches that detect the minimum or maximum level in bins, silos and hoppers filled with any kind of easy flowing solids, e.g. granules or pellets like grains, granular plastics, foods, etc. The units are ideal for detecting materials with bulk densities of 20 grams per liter and higher.

How it works

The signal from the electronic circuit of the **CV600/CV630/CV650** excites the stainless steel rod of the probe to vibrate on its resonance frequency of approx. 460Hz. When material covers the rod of the probe the vibration stops. This is sensed by the electronic circuit which forces a binary output signal to switch. When the rod gets uncovered, the vibration restarts and the output signal switches back.

Advantages

- The vibration technique of the **CV600/CV630/CV650** offers many unique advantages over alternative level sensing technologies:
 - easy installation, no calibration required
 - no problems at material changes in the silo: the function is independent from material characteristics, e.g. dielectricity
 - no readjustment required: unaffected by environmental changes e.g. temperature, pressure, humidity
 - unaffected by dust clouds and agitation
 - no maintenance required: the vibration has a self cleaning effect
 - high durability: no moving parts, no wear-out

- reliable function due to unique patented single rod design
 - the **CV600/CV630/CV650** have only one single rod that comes in touch with the material to be detected; thus the typical bridging problem, where material builds a bridge from one rod to the other, well known at instruments with so called "tuning fork" design, is ruled out
 - material build-up on the container wall has no influence on the function of the units as only the tip of the vibrating blade is sensitive and not the base

- Fail-safe
the electronic circuit of the **CV600/CV630/CV650** indicates power failure: if power supply fails the output drops into alarm condition

- High quality
 - solid stainless steel construction
 - enclosure aluminium diecast, protection IP66 / IP67
 - designed and manufactured at PTL in Germany according to DIN EN ISO9001:2008 and with the background of over 30 years of experience in the field of vibrating level switches

- ATEX-approvals available for dust- and gas-ex

- Low cost
In spite of all the above mentioned advantages the **CV600/CV630/CV650** are available for a very attractive price.

Specifications

Enclosure: diecast aluminium, protection IP 66 / 67, (IP65 for remote electronics installation)
1 cable duct M16 for cable diameter 4,5 to 10 mm, (optional 2nd cable duct)

Probe: stainless steel 1.4301 / AISI 304
process connection: thread 1" EN10226 (equals BSPT) or 1" NPT
insertion length approx. 157mm
resonance frequency approx. 460 Hz
max. load upon the end of the blade: 80N

Electronics: wide range power supply with relay output:
power supply: wide range 20 ... 250V AC/DC
relay output: one potential-free change-over contact (SPDT)
max. switching voltage: 250V-AC, 30V-DC
max. switch current: 5A (NO-contact), 3A (NC-contact)
max. switching power: 1250VA, cos φ = 1, 150W for DC
indication: red LED on PCB for relay status, yellow LED for power
power consumption: 3 VA

2-wire version with 8/16mA current output:

power supply: 20...30V-DC
output: 8 / 16mA,
conversion into relay signal by the supply- and analyzing unit **CV2000AE** or similar signal converters
indication: green LED on PCB
power consumption: <0,5W

time delay: 1 second from stop of vibration
(both versions) 2 to 5 seconds for start of vibration

Material to be detected: non sticky, dry and easy flowing granular solids
min. density 20 grams per liter
grain size approx. Ø0,5 to max. 20mm

Max. pressure inside bin: 10 bar

Ambient temperatures: electronics: -20°C ... + 60°C
process: -20°C ... + 80°C
-20°C ... + 150°C (special model HT)

Switching Logic

The **CV600** operates in either high- or low level alarm mode. The mode is selected by a jumper on the PCB. The output status is indicated by a LED on the PCB.

H: high level alarm:
The relay is deenergized, (LED off), when the rod is covered by material or power has failed.
The 2-wire version takes 16mA at this state and the LED is on.

L: low level alarm:
The relay is deenergized, (LED off), when the rod is free or power has failed.
The 2-wire version takes 16mA at this state and the LED is on.

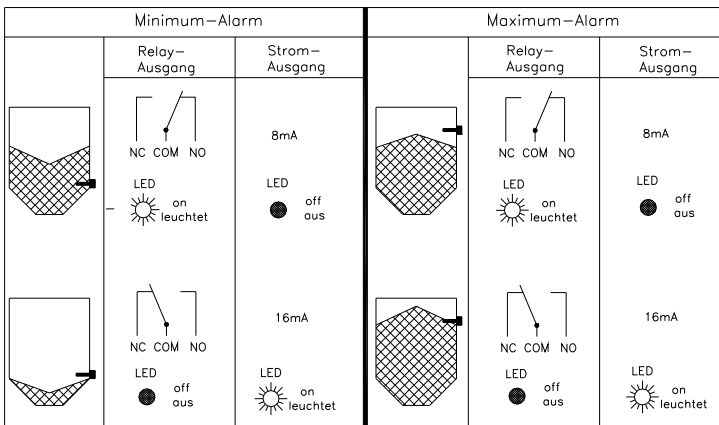

Versions

- CV600: compact model with fixed insertion length of 157mm measured from the tip of the vibrating rod to the beginning of the thread
- CV630: model with welded pipe extension, insertion length up to 1000mm
- CV650: model with cable extension, insertion length up to 4000mm

Special Models

➤ Remote Electronics Installation

For some applications it is necessary to keep the electronics apart from the container, e.g. if the ambient temperature at the silo exceeds the max. allowed 60°C or if the silo is exposed to heavy vibrations or shocks. For these applications the remote electronics installation can be used.

It is available in two versions: (drawings see page 9)

- version with standard housing and terminal PCB on probe
- version with angled screw coupling on probe

The standard length of the cable between probe and electronics is 2 meters. Longer cables are available as well.



➤ High Temperature Model HT

For applications with process temperatures higher than 80°C up to 150°C. In order to avoid that the allowed ambient temperature of the electronics (max. 60°C) will get exceeded due to thermal conduction via the probe a temperature insulating tube is mounted in between the probe and the enclosure. Instead it also is possible to install the electronics at a place with low ambient temperature by using the remote electronics installation.

Drawing see page 10.



Options

The following options are available:

- second cable gland (not available in combination with remote electronics)
- enclosure powder coated grey, blue, orange
- Ex-approvals according to ATEX directive 2014/34/EU
- special model "Extreme Sensitivity": senses material down to 10g/l

Approvals

- CE approval according to the following directives:
 - EMC-directive 2014/30/EU
 - Low Voltage-directive 2014/35/EU

- Ex-approvals according to ATEX-directive 2014/34/EU:

- Dust-Ex: ATEX II 1/2D Ex ta/tb IIIC T95°C Da/Db

- Gas-Ex: ATEX II 1G Ex ia IIB T4 Ga or II 1/2G Ex ia IIB T4 Ga

for use at zones 20/21/22

for use at zones 0, 1 or 2

Details see page 5.



Products with ATEX Approval: Protection Level, Marking, Zones

Dust-Ex, Protection by Enclosure: CV600StEx

The vibrating level switch **CV600StEx** can be used in the presence of combustible dust according to ATEX directive 2014/34/EU: equipment group II, category 1/2D or 1/3D for remote electronics installation.

Marking according to ATEX:

The **CV600StEx** has a nameplate on the enclosure showing the following data:

	PTL Hermann GmbH Kellermatten 3 - 79618 Rheinfelden - Germany - info@ptl-hermann.com www.ptl-hermann.com	
		CV600DIN-StEx Ser. No.: xxxxxStEx Power Supply: 20...250V AC/DC Relay Output: NO max. 5A @ 250V NC max. 3A @ 250V Power Consumption: 3 VA
	II 1/2D Ex ta/tb IIIC T95°C Da/Db Tamb (Gehäuse, Zone 21): -20...+60°C	IBExU03ATEX1033 IP6X Tprocess (Sonde, Zone 20): -20...+80°C

Allocation of Categories, EPL and Zones:

Component	Category	EPL Equipment Protection Level	can be used in Zone
Probe	1 D	Da	20, 21 or 22
Enclosure with PCB	2 D	Db	21 or 22
Remote Electronics Installation	3 D	Dc	22

Protection according to EN 60079-31:

- protection by dust-tight enclosure IP6X
- limited surface temperatures of the apparatus

Maximum surface temperatures:

Zone	max. perm. amb. temperature	max. surface temperature at failure	heat up due to failure
Zone 20	80°C for standard units 150°C for high temperature (= process temp.)	80°C for standard 150°C for high temp	0 K 0 K
Zone 21/22	60°C	95°C	+35 K

The 35K maximum heat up of the enclosure surface results on 25K heat up of the electronics at failure and additional 10K due to heat conduction via the probe in cases the process temperature is higher than 60°C.

Gas-Ex, Protection Concept Intrinsic Safety: CV600Exi

The vibration type level switch **CV600Exi** has approval according to ATEX directive 2014/34/EU for the use in explosive atmospheres as follows:

- Gas-Ex: II 1 G Ex ia IIB T4 Ga or II 1/2G Ex ia IIB T4 Ga
- Dust-Ex: II 1 D Ex ia IIIC TX Da or II 1/2D Ex ia IIIC TX Da

Architecture

The units come with a split architecture allowing the probe with low energy 8/16mA-output to be installed within the explosive atmosphere whereas the supply and analyzing unit **CV2000AE[Exi]** with wide range power supply and relay output must be installed at the non explosive area.

For installation it is important to know that the associated apparatus CV2000AE[Exi] is not galvanically isolated. Special requirements according to EN60079-14 have to be considered.

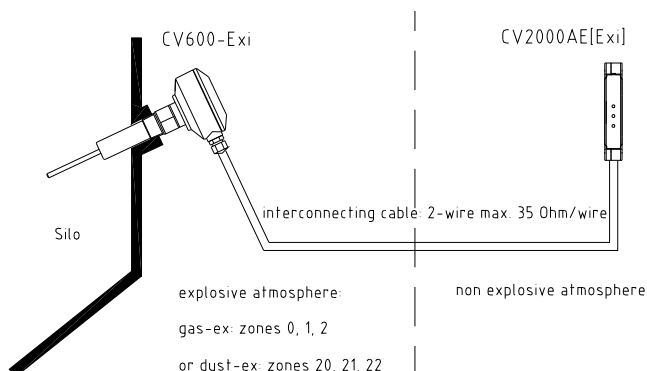

Applied standards: EN60079-0, EN60079-11, EN60079-26, EN60079-31.

Marking according ATEX:

The units have a nameplate showing the following details:

	PTL Hermann GmbH Kellermatten 3 - 79618 Rheinfelden - Germany		www.ptl-hermann.com info@ptl-hermann.com
		CV600DIN-Exi Ser.No.: xxxxxxExi IExU09ATEX1005X	Ui=23,7V-DC Ii=167mA Pi=958mW Ci: neglig.; Li: neglig. Ta=-20...+60°C IP6X
	II 1G Ex ia IIB T4 Ga II 1D Ex ia IIIC TX Da	II 1/2G Ex ia IIB T4 Ga II 1/2D Ex ia IIIC TX Da	

Allocation of Categories and Zones:

Apparatus type	Marking	Component	Category	for Gas-Ex Zones	for Dust-Ex Zones
Cat.1-apparatus	1G Ex ia IIB T4 Ga 1D Ex ia IIIC TX Da	Probe	1G or 1D	0, 1 or 2	20, 21 or 22
		Encl. with electronics	1G or 1D	0, 1 or 2	20, 21 or 22
Cat.1/2-apparatus	1/2G Ex ia IIB T4 Ga 1/2D Ex ia IIIC TX Da	Probe	1G or 1D	0, 1 or 2	20, 21 or 22
		Encl. with electronics	2G or 2D	1 or 2	21 or 22

Allowed ambient temperatures Tamb:

Apparatus type	Unit type	Temp.-class	max. surface temperature	Tamb at electronics	Tamb at probe without temp. insul. tube	Tamb at probe with temp. insul. tube
Cat.1-apparatus	Standard units CV600Exi	T4	Probe: 60°C Encl.: 75°C	-20 ... +60°C	-20 ... +60°C	combination not available
Cat.1/2-apparatus	Standard units CV600Exi	T4	Probe: 60°C Encl.: 85°C	-20 ... +60°C	-20 ... +80°C	combination not available
	High temp. units CV600Exi-HT	T4	Probe: 108°C Encl.: 85°C	-20 ... +60°C	combination not available	-20 ... +108°C *
	High temp. units CV600Exi-HT	T3, T2, T1	Probe: 150°C Encl.: 85°C	-20 ... +60°C	combination not available	-20 ... +150°C *

* listed temperatures already include reduction to 80% according to EN1127-1 chpt. 6.4.2

Technical data referring to intrinsic safety:

- Ui=23,7V, Ii=167mA, Pi=958mW, Li: negligible, Ci: negligible
- Power supply and signal conversion is made by the associated apparatus CV2000AE[Exi].

Special requirements according to EC-Type Examination No. IExU09ATEX1005X:

- For functional reasons the probes are connected to earth. The enclosure of the apparatus must be connected to the equipotential bonding system.
- Special requirements for associated apparatus without galvanic isolation according EN 60079-14 have to be observed.
- In case the units are used as category 1 apparatus in zones 0 or 20 the units must be installed in a way that the generation of sparks due to friction or strokes on the aluminium housing is eliminated.
- The allowed temperature range and the mounting instructions according to the instruction manual have to be observed.
- In case the units are used as category 1 / 2 apparatus at gas explosive atmospheres the 1 1/2" thread which serves for process connection and separation of zones 0 and 1 must be sealed in a way that protection IP67 according to EN60529 is achieved.

CV2000AE[Exi]

The **CV2000AE** is a supply and analysing unit for the vibration type level switch **CV600** with 8/16mA output. For the intrinsically safe probe **CV600Exi** the **CV2000AE [Exi]** has approval according to ATEX 2014/34/EU as the associated apparatus.

Function:

The **CV2000AE** supplies the connected probe with a DC voltage. Depending on the level inside the bin, (probe covered with filling material or not), the electronics of the probe takes more or less current. This current change is sensed by the **CV2000AE** and gets converted into a relay output. The interconnecting cable between probe and **CV2000AE** gets monitored permanently for short circuit and line break. In case of short circuit or line break an additional relay output switches.



Technical Data:

- Enclosure: Polyamid enclosure for carrier rail mounting 35mm according to EN50022 dimension 114x35x99mm; protection IP20
- Electronics:
 - Power Supply: 20...250V AC/DC; max. 3VA
 - Output power supply for probe: 20V-DC (without load)
 - Relay Output: one potential free change over contact (SPDT), max. 5A/250V
 - Failure indication: detection of line break and short circuit by additional relay
 - Connection cable to probe: 2-wire, max. 35 Ohms per wire
 - Indication:
 - yellow LED: power supply
 - green LED: relay status
 - red LED: failure indication (line break and short circuit)
- Temperature: -20°C ... + 60°C

Approvals:

- The **CV2000AE** meets the following European directives:
 - EC EMC directive 2014/30/EU
 - EC low voltage directive 2014/35/EU
- The following standards have been applied:
 - EN 61326 05.04
 - EN 61010-1



The **CV2000AE [Exi]** has approval according to ATEX 2014/34/EU as the associated apparatus for intrinsically safe vibration type level switches as follows:

- Gas: II (1)G [Ex ia Ga] IIB
- Dust: II (1)D [Ex ia Da] IIIC

	PTL Hermann GmbH Kellermatten 3 - 79618 Rheinfelden - Germany -	www.ptl-hermann.com info@ptl-hermann.com
	CV2000AE [Exi] Ser.No.: xxxxxxExi	Power Supply: 20...250V AC/DC Power Consumption: 3VA Uo=23,7V; Io=166mA; Um=375V Co=390nF; Lo=4,3mH, Kennlinie linear
	II (1) G [Ex ia Ga] IIB II (1) D [Ex ia Da] IIIC	IBExU09ATEX1006 X Ta=-20 ... +60°C

Special requirements according to EC-Type Examination No. IBExU09ATEX1006X:

According to the EC-Type Examination Certificate of the **CV2000AE [Exi]** the following special requirements have to be fulfilled:

At the installation the additional requirements for associated apparatus without galvanic isolation according to EN 60079-14 have to be considered.

Dimension

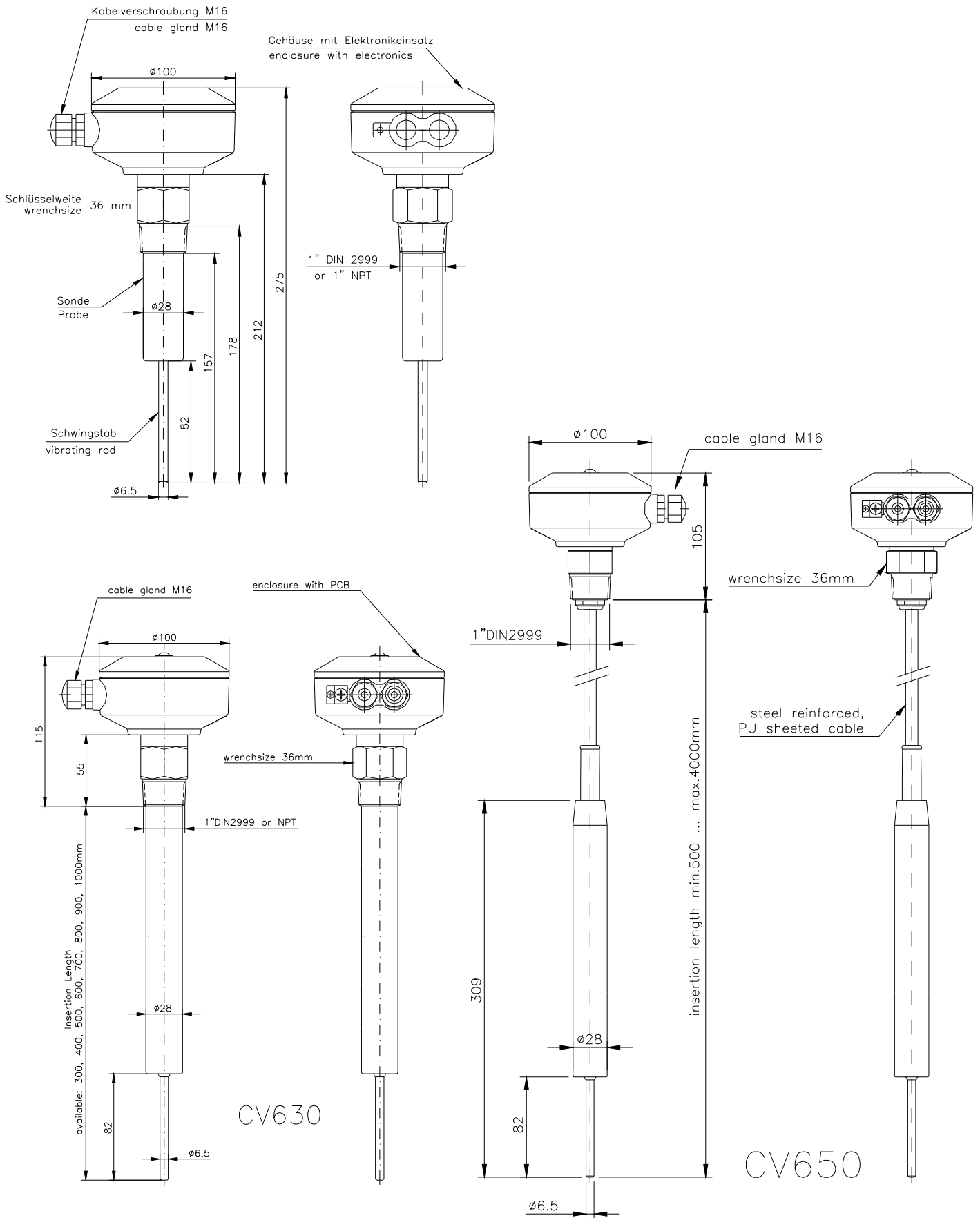

- remote electronics installation with enclosure and terminal PCB

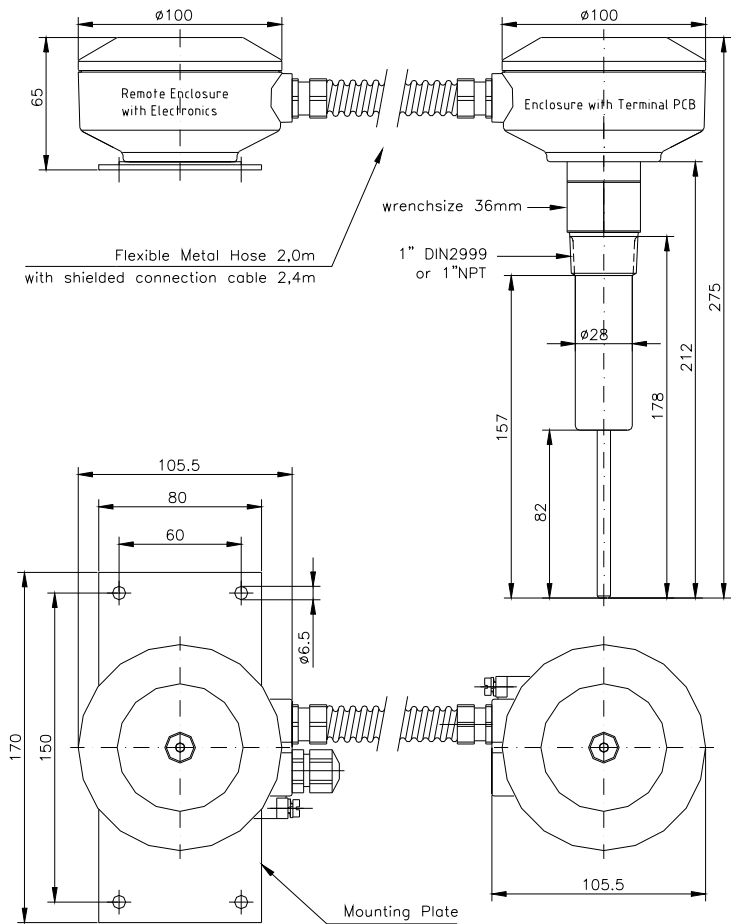

- remote electronics installation with angled screw coupling

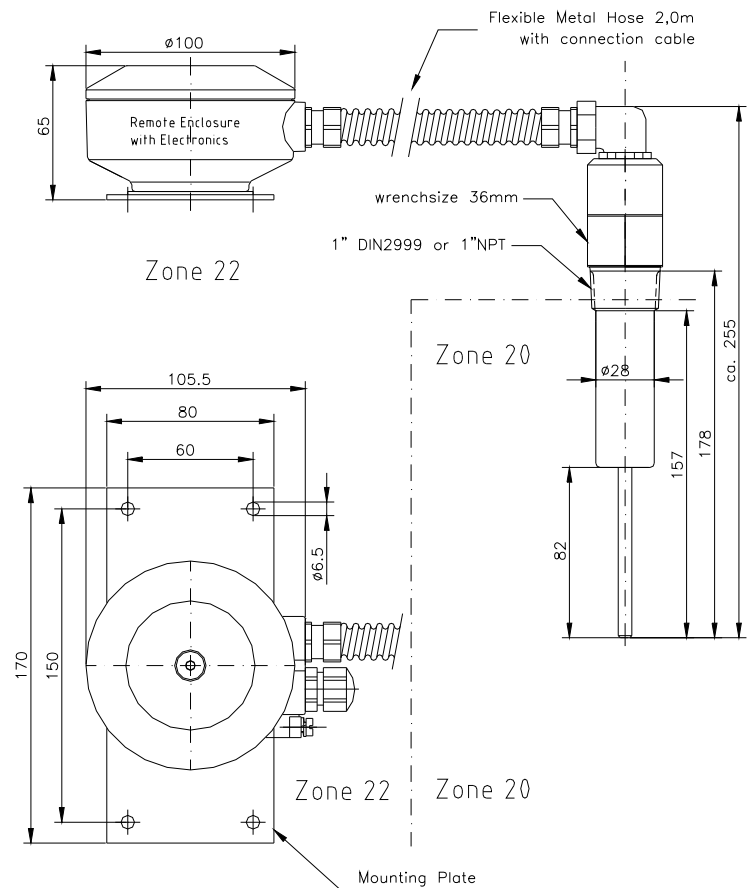

- special model HT with temperature insulating tube

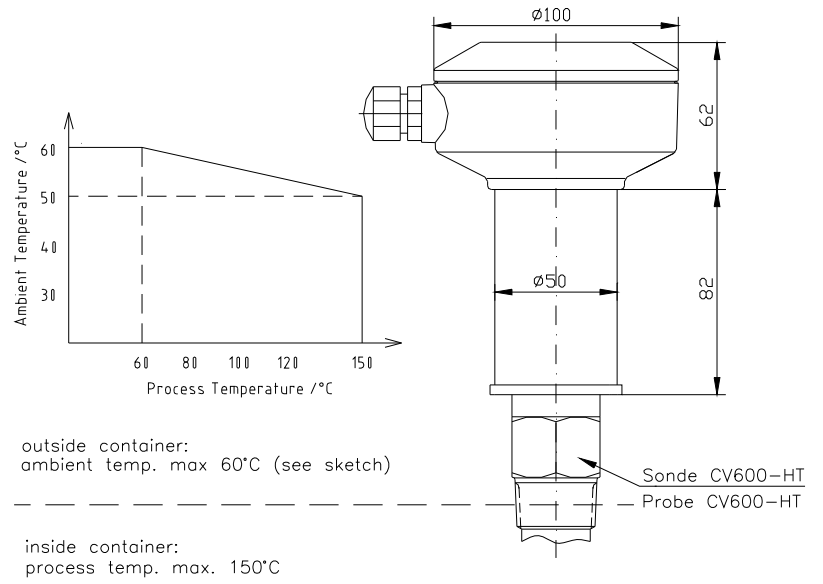

- CV2000AE[Exi]

