

PS75 – Rugged Cylindrical Pressure Switch

- ▶ Side Mounted DIN Connection
- ▶ Top Mounted Electrical Connection
- ▶ 5 to 6000 psi (0.35 to 414 bar)
- ▶ Wear Disc Design for Longer Life

Gems PS75 Series have all metal surfaces for overload stops and deliver reliable operation under extremely high pressure surges. They are designed with a wear disc and cushioning ring for increased life. The switches use a piston/diaphragm design, which combine the high proof pressure of piston technology with the sensitivity of a diaphragm design. They can be field or factory adjusted.

Specifications

Switch	SPST; SPDT
Repeatability	See Table 1
Wetted Parts	
Diaphragm	Nitrile (optional Viton®, Neoprene or EPDM)
Fitting	Zinc-Plated Steel (optional 316 Stainless Steel)
Housing	Brass or Zinc-Plated Steel (optional 316 Stainless Steel)
Electrical Termination	DIN 43650A IP65; Conduit with Flying Leads IP65; Flying Leads IP65
Proof Pressure	7500 psi (517 bar) except range 10: 500 psi (35 bar)
Burst Pressure	9000 psi (621 bar)
Approvals	CE, UL Approved units available
Weight, Approximate	Steel: 0.6 lbs. (0.27 kg)

Recommended Operating Temperature Limits

Diaphragm Material	Circuit Codes	
	-A, -B, -C	-A, -B, -C with -RD option
Nitrile (Std)	15°F to 185°F (-9°C to +85°C)	15°F to 250°F (-9°C to +121°C)
Viton®	0°F to 185°F (-18°C to +85°C)	0°F to 250°F (-18°C to +121°C)
EPDM	-10°F to +185°F (-23°C to +85°C)	-10°F to +250°F (-23°C to +121°C)
Neoprene	-10°F to +185°F (-23°C to +85°C)	-10°F to +250°F (-23°C to +121°C)

Note: Switches may function below the cold temperature limit but the set points and deadband will increase. Consult factory for details.

Electrical Switch Ratings

Circuit Code	AC	DC
-A, -B, -C¹	5 amps @ 125/250 Volts	5 amps resistive, 3 amps inductive @ 28 Volts
-A, -B, -C²	1 amp @ 125 Volts	1 amp resistive, 0.5 amp inductive @ 28 Volts

Notes:

1. Without Gold Contacts Option (-G).
2. With Gold Contacts Option (-G).

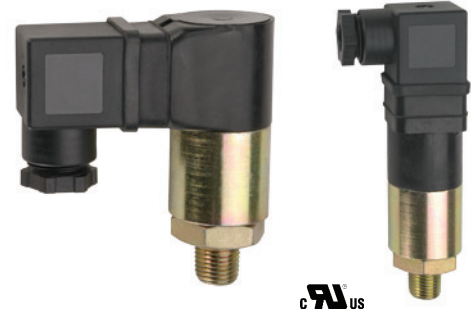

Dimensions

Right Angle DIN 43650A with Cable Clamp

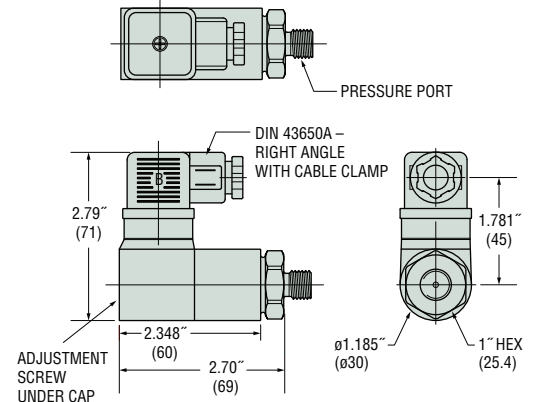

Flying Lead

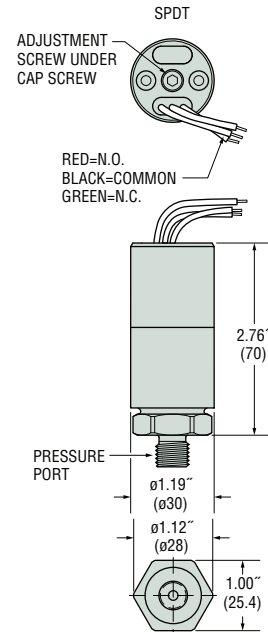

How To Order

Use the **Bold** characters from the chart below to construct a product code. Please reference Notes.

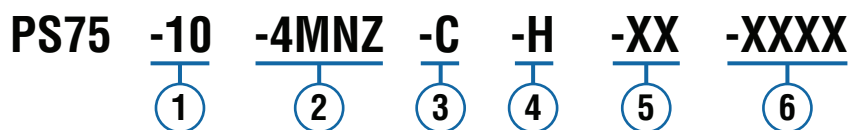

1 Pressure Range Code

Insert Pressure Range Code from Table 1, below.

2 Pressure Fitting¹

12L14 Zinc-Plated Steel

- 2MNZ = 1/8" NPTM
- 4MNZ = 1/4" NPTM
- 4FNZ = 1/4" NPTF
- 4MGZ = 1/4" BSPM (G type)
- 4FGZ = 1/4" BSPF (G type)
- 4MSZ = 7/16"-20 SAE Male
- 6MSZ = 9/16"-18 SAE Male
- 4SSZ = 7/16"-20 SAE Male Swivel

316 Stainless Steel

- 4MNS = 1/4" NPTM
- 4MGS = 1/4" BSPM (G type)
- 4FGS = 1/4" BSPF (G type)
- 4FNS = 1/4" NPTF
- 6MSS = 9/16"-18 SAE Male

3 Circuit

- A = SPST/N.O.
- B = SPST/N.C.
- C = SPDT

4 Electrical Termination

- FLXX = Flying Leads²
- FLSXX = Flying Leads w/PVC Shrink Tubing²
- ELXX = 1/2" NPT Male Conduit w/Flying Leads³
 - H = DIN 43650A Male Half Only⁴
 - HR = Right Angle DIN 43650A Male Half Only⁴
 - HC = DIN 43650A 9mm Cable Clamp⁴
 - HCR = Right Angle DIN 43650A 9mm Cable Clamp⁴
 - HN = DIN 43650A with 1/2" Female NPT Conduit⁴
 - HNR = Right Angle DIN 43650A with 1/2" Female NPT Conduit⁴

5 Options

- V = Viton[®] Diaphragm
- N = Neoprene Diaphragm
- E = EPDM Diaphragm
- G = Gold Contacts
(for loads less than 12 mA @ 12 VDC)
- RD = Reduced Differential (25% reduction typical)
- OF = Oil Free Cleaned⁵
- R = Restrictor (low damping coefficient) Brass
- SR = Spiral Restrictor (high damping coefficient)
300 Series Stainless Steel⁶
- WF = Weather Pack Connector, Female
- WM = Weather Pack Connector, Male
- DE = Deutsch Connector, Male, DT04 Series

6 Fixed Set Point (optional)

A. Specify set point **-FS** (in PSI or BAR, see example)⁷

B. Set Point Actuation

R on Rising Pressure

F on Falling Pressure

Example: **-FS1BARF** for 1 BAR Falling

or **-FS20PSIR** for 20 PSI Rising

Notes:

1. Manifold mounts available. Consult factory.
2. 18" is standard. Specify lead length in inches (max. 48"). e.g. **-FL18** or **-FL30**.
3. 18" is standard. Specify lead length in inches (max. 48"). e.g. **-EL18** or **-EL30**.
4. DIN connectors require **-C** SPDT circuit.
5. Requires stainless steel pressure fitting.
6. **-SR** will result in wider deadbands and slower response times.
7. Set Point must be within Pressure Range selected in Step 1.

Table 1 — Pressure Range Codes

For Circuit Codes -A, -B and -C

Pressure Range Code	Pressure Range	Accuracy*	Average Deadband**
10	5-25 psi (0.35-1.7 bar)	±1.0 psi (0.07 bar) +2% of setting	3 psi (0.21 bar) +5% of setting
20	15-75 psi (1.0-5.2 bar)	±2.5 psi (0.17 bar) +2% of setting	5 psig (0.34 bar) +10% of setting
30	50-150 psi (3.5-10.3 bar)	±6 psi (0.41 bar) +2% of setting	15 psig (1.03 bar) +13% of setting
40	150-650 psi (10.3-44.8 bar)	±15 psi (1.03 bar) +2% of setting	25 psi (1.72 bar) +14% of setting
50	500-1750 psi (34.5-121 bar)	±25 psi (1.72 bar) +2% of setting	55 psi (3.79 bar) +15% of setting
60	1000-3500 psi (69-241 bar)	±45 psi (3.10 bar) +3% of setting	100 psi (6.89 bar) +16% of setting
70	2500-6000 psi (172-414 bar)	±80 psi (5.51 bar) +4% of setting	200 psi (13.8 bar) +17% of setting

* Accuracy and set point of units may change due to the effects of temperature.

** In certain applications deadband can be tailored and controlled to customer specifications. Consult factory for details.