

**Frost protection thermostats, mechanical, one-step, with switching output**

FST -1 / 5 / 7 / 8

The mechanical frost protection thermostat / frost monitor **THERMASREG® FST** with switching output, fully-active sensor rod, with automatic reset, or with mechanical locking and manual reset, is available with capillaries in lengths of 0.6 m, 1.8m, 3m, 6 m, or 12 m. This frost protection monitor is used for air- and water-side temperature monitoring at heat exchangers, water circulation systems, and heating registers to prevent freezing up and to avoid frost damages, e.g. in ventilation and air conditioning ducts. All devices are self-secure with sensor breakage detection. In case of damage to the capillary tube–membrane system, the relay automatically switches to heating function. **FST-3** can also be used for monitoring liquids. The sensor tube can be installed inside an immersion sleeve. Mounting clamps **MK-05-K** are included in the delivery.



**TECHNICAL DATA**

Switching capacity:	10 (2) A, AC 250 V; because of gold-plated switching contacts also switching of signal voltages < 24 V
Setting range:	-10...+15 °C / +14 °F...+59 °F, factory setting to w = +5 °C (+41 °F)
Operating difference:	2 ± 1 K (3.6 ± 1.8 °F)
Reproducibility:	± 0.5 K (± 0.9 °F)
Contact:	dust-proof micro switch as single-pole potential-free changeover contact
Sensor responding length:	approx. 40 cm
Length of capillary tube:	see table of types (0.6...12 m)
Resetting:	<b>FST-xD</b> automatic <b>FST-xD-HR</b> manual
Permissible medium:	<b>FST-1/5/7/8</b> air <b>FST-3</b> water
Ambient temperatures:	maximum operating temperature: +70 °C (+158 °F) minimum operating temperature: w + min. +2 °C (min. +3.6 °F) storage / transport: -30...+70 °C (-22...+158 °F)
Process connection:	by mounting clamps <b>MK-05-K</b> (included in the scope of delivery)
Enclosure:	plastic, material polyamide, 30% glass-globe-reinforced, with quick-locking screws (slotted / Phillips head combination), colour traffic white (similar to RAL 9016)
Enclosure dimensions:	126 x 90 x 50 mm (Tyr 2)
Cable gland:	M 16 x 1.5; including strain relief
Other materials:	mechanical sheet metal parts: galvanised steel capillary tube: copper capillary tube filling: R 507 switching contacts: Ag / Ni (90% / 10%) gold-plated (3 µm)
Installation length:	arbitrary
Electrical connection:	0.14 - 2.5 mm²
Protection class:	I (according to EN 60 730-1)
Protection type:	IP 65 (according to EN 60 529)
Standards:	CE conformity, EMC directive 2014 / 30 / EU, low-voltage directive 2014 / 35 / EU
<b>FUNCTION</b>	Contact C-2: danger of frost / sensor breakage Contact C-3: normal operation
For further information and accessories see next page...	

FST-3



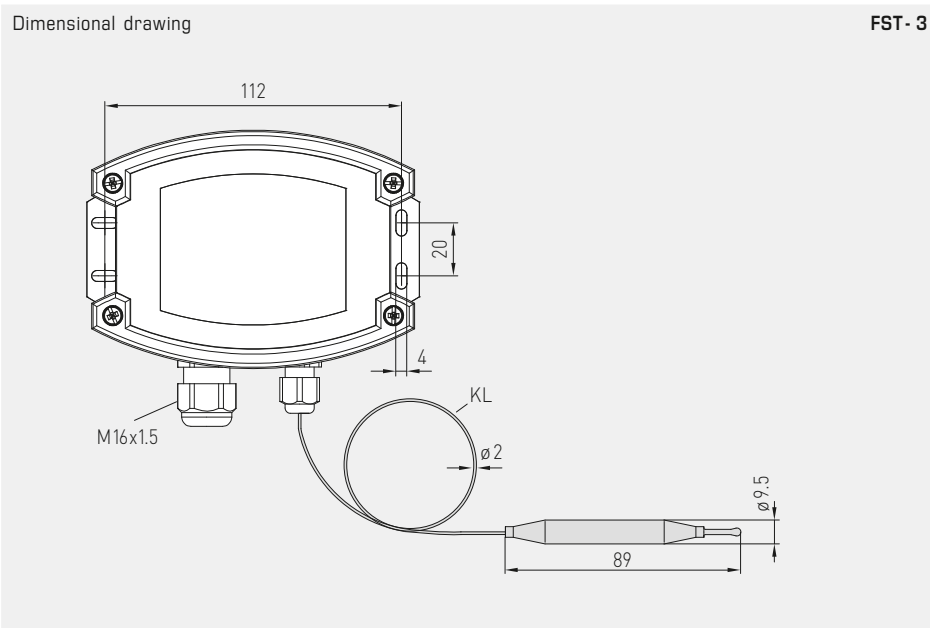
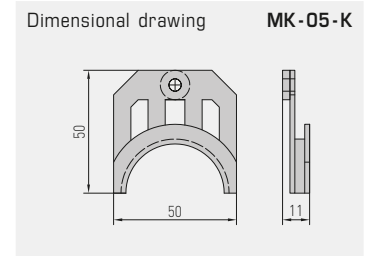
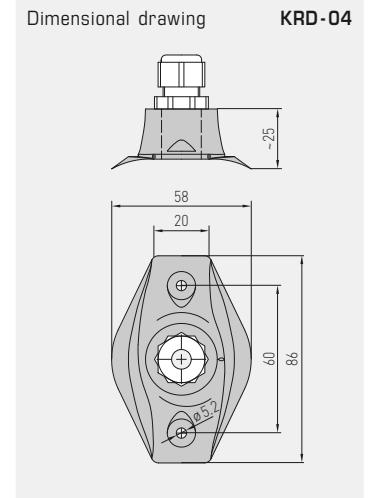
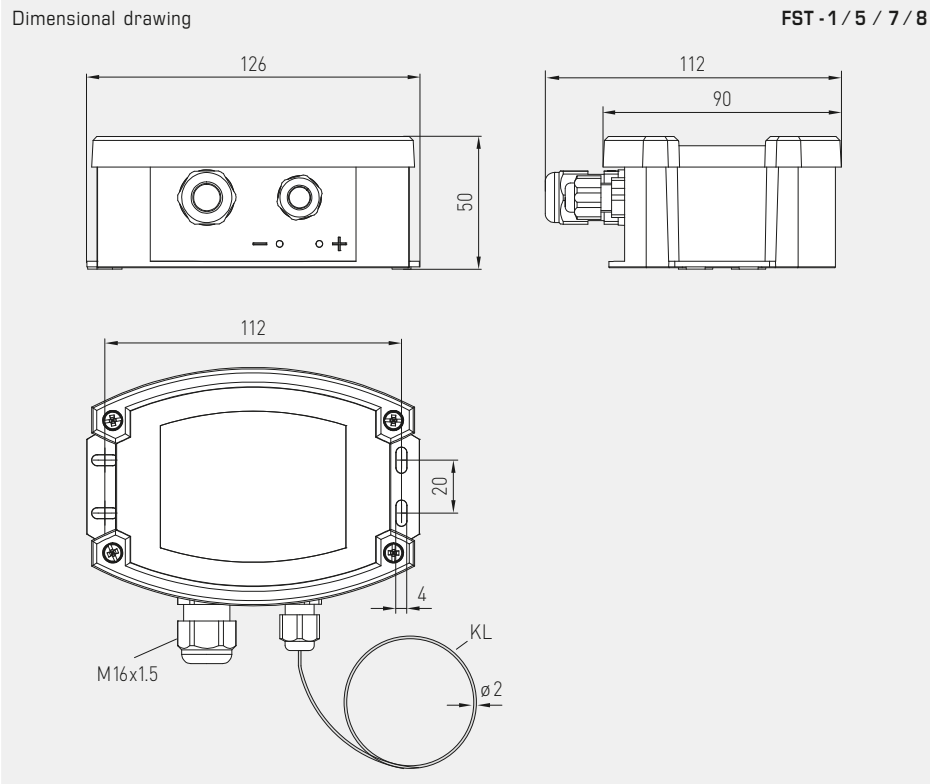

**Frost protection thermostats, mechanical, one-step, with switching output**

**FST -1 / 5 / 7 / 8 -HR**  
(manual rest)

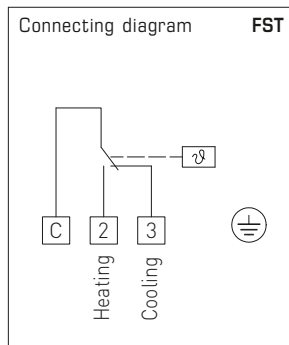
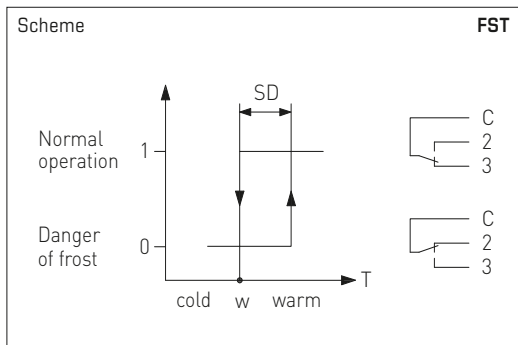

**FUNCTION**

The switch inside frost protection thermostat **FST** responds (closes contact C-2) when temperature falls below the preset temperature setpoint over a capillary tube length of at least 40 cm. Simultaneously contact C-3 breaks and can be used as a signal contact. Resetting (closing contact C-3) happens automatically when temperature rises above the preset setpoint value again (on type **FST-xR** resetting must be done manually by pressing the reset button).

The **FST** is "intrinsically safe", i.e., in the event of damage to the capillary tube-membrane system, it automatically switches to the heating function. Contact C-2 closes and therefore can be used as operating contact. The air temperature is detected over the entire sensor length (capillary tube). The gas-filled (R507) membrane system and the capillary tube constitute one measuring unit, which is mechanically coupled to the microswitch.

**Capillary tube:** The capillary tube is laid uniformly at the hot side of the air heater to be protected (in case of air coolers in front of the air cooler) at a distance of approx. 5 cm crosswise to the heat exchanger tubes over the entire area. For test purposes, it is recommended to make a loop of approx. 20 cm directly underneath the enclosure and before entering the air duct. To avoid damaging the capillary tube, a minimum bending radius of 20 mm must be observed. Installation is facilitated by using the mounting clamps available under accessories.

**Frost simulation:** The frost situation can be simulated and functioning of the device can be tested by dipping the capillary tube testing loop into a pot filled with ice water.

**FST-3-HR**  
(manual rest)



**WS-03**

Sunshade and weather protection (optional)





**FST-xD**  
TW = temperature monitor  
(automatically switching)



**FST-xD-HR**  
TB = temperature limiter  
(manual reset)



THERMASREG® FST – Frost protection thermostats, mechanical

Type / WG03	Temperature Range	Thermal Operating Difference (fixed) approx.	Length of Capillary	Permissible Medium	Item No.	Price
<b>FST-xx D</b>						<b>TW</b>
FST-1D *	-10...+15 °C	2K (± 1 K)	6.0 m	air	1102-1021-0102-000	<b>71,95 €</b>
FST-3D *	-10...+15 °C	2K (± 1 K)	1.8 m	air / water	1102-1023-0102-000	<b>73,56 €</b>
FST-5D *	-10...+15 °C	2K (± 1 K)	3.0 m	air	1102-1022-0102-000	<b>70,33 €</b>
FST-7D *	-10...+15 °C	2K (± 1 K)	12.0 m	air	1102-1025-0102-000	<b>126,70 €</b>
FST-8D	-10...+15 °C	2K (± 1 K)	0.6 m	air	1102-1024-0102-000	<b>69,58 €</b>
<b>FST-xx D- HR</b>						<b>TB</b>
FST-1D-HR *	-10...+15 °C	2K (± 1 K)	6.0 m	air	1102-1021-1102-000	<b>84,83 €</b>
FST-3D-HR *	-10...+15 °C	2K (± 1 K)	1.8 m	air / water	1102-1023-1102-000	<b>86,44 €</b>
FST-5D-HR *	-10...+15 °C	2K (± 1 K)	3.0 m	air	1102-1022-1102-000	<b>83,23 €</b>
FST-7D-HR *	-10...+15 °C	2K (± 1 K)	12.0 m	air	1102-1025-1102-000	<b>139,59 €</b>
FST-8D-HR	-10...+15 °C	2K (± 1 K)	0.6 m	air	1102-1024-1102-000	<b>82,46 €</b>
Features:	FST-xD	<b>TW = temperature monitor (automatically switching)</b>				
	FST-xD-HR	<b>TB = temperature limiter (manual reset)</b>				

Accessories

<b>KRD-04</b>	Capillary tube gland bracket	7100-0030-7000-000	<b>7,52 €</b>
<b>MK-05-K</b>	Mounting clamps (6 pieces) plastic (*= included in the scope of delivery)	7100-0034-1000-000	<b>8,33 €</b>
<b>TH-MS-01</b>	Immersion sleeves, brass, for FST-3	7100-0011-5402-000	<b>13,11 €</b>
<b>TH-VA-02</b>	Immersion sleeves, stainless steel, for FST-3	7100-0012-5402-000	<b>34,37 €</b>
<b>WS-03</b>	Sunshade and weather protection, 200 x 180 x 150 mm, stainless steel	7100-0040-6000-000	<b>37,74 €</b>

For further information see last chapter!